

1.0 SCOPE

Instructions for the removal and replacement of conveyor belt on an existing infrared belt furnace where the furnace chamber and/or cooling sections are being replaced.

2.0 EQUIPMENT AFFECTED

Applies to infrared belt furnaces manufactured by LCI or RTC from 1972 to present.

2.1 TOOLS

- 2.2 Diagonal cutters, long nose pliers, long rod or wire.
- 2.3 When installing a transport belt it is helpful to have an assistant for the task.

3.0 PREPARATION

The following items should have been completed before the chamber is removed.

3.1 Shut off Utilities

- 3.1.1 Shut off facility breaker to isolate the furnace from the power source.
- 3.1.2 Shut of process gas supply.

3.2 Relieve Roller Tension

3.2.1 Pinch Roller Air Cylinder Tensioner. If equipped with air piston tensioner, locate the copper reservoir. Remove cap from pressure release port. Push in stem to relieve gas pressure. When pressure gauge shows zero, tension has been released. Replace cap.

3.2.2 Spring Type: no preparation necessary.

3.3 Remove Belt Tensioner Weight

3.3.1 If present on the furnace, remove the metal or UHMW weight bar from the lower exit section of the furnace.

3.3.2 To relieve the belt tension, lift the weight bar out of the belt drop guide (or UCD tank if so equipped) and set aside for reinstallation.



Figure 1-1 LA-310 Front View

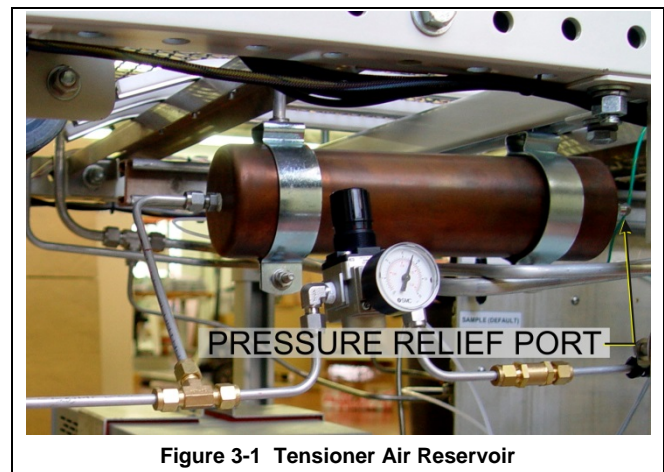

Figure 3-1 Tensioner Air Reservoir

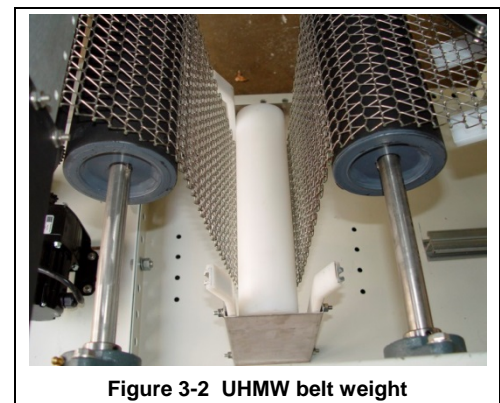

Figure 3-2 UHMW belt weight

3.4 Sever Old Belt

3.4.1 At the exit, cut one of the cross-section wires travelling the width of the belt. Snip both ends of the wire.

3.4.2 Remove the wire by pulling straight through the belt.

3.4.3 Separate the belt.



Figure 3-3 Cut Wire at Ball Joint



Figure 3-4 Second Cut at Opposite Side

4.0 Remove Old Belt

4.1.1 At the entrance of the furnace, remove the belt by grasping the belt on either side of its width and pulling evenly and firmly until the top part of the belt is removed from the chamber. Roll the top portion of the belt.

4.1.2 Grasping the belt on either side of its width and pulling evenly and firmly to remove the bottom portion of the belt.

4.1.3 Continue to roll the old belt as shown in the figure until it is free of the furnace chamber area.

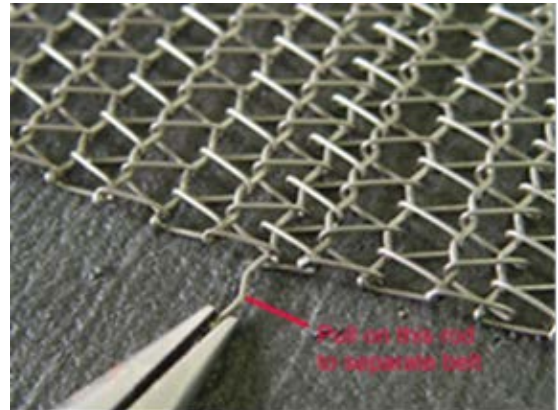

Figure 3-5 Remove belt wire

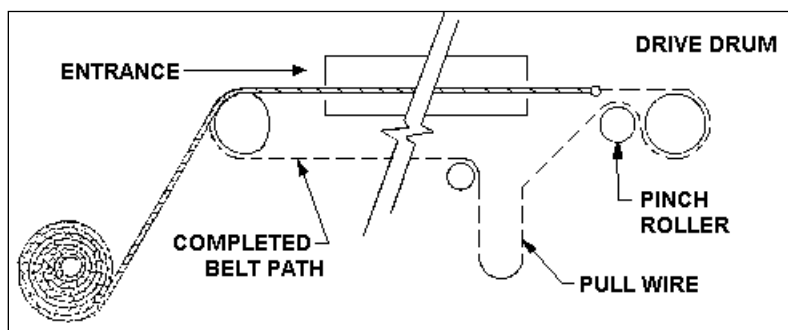
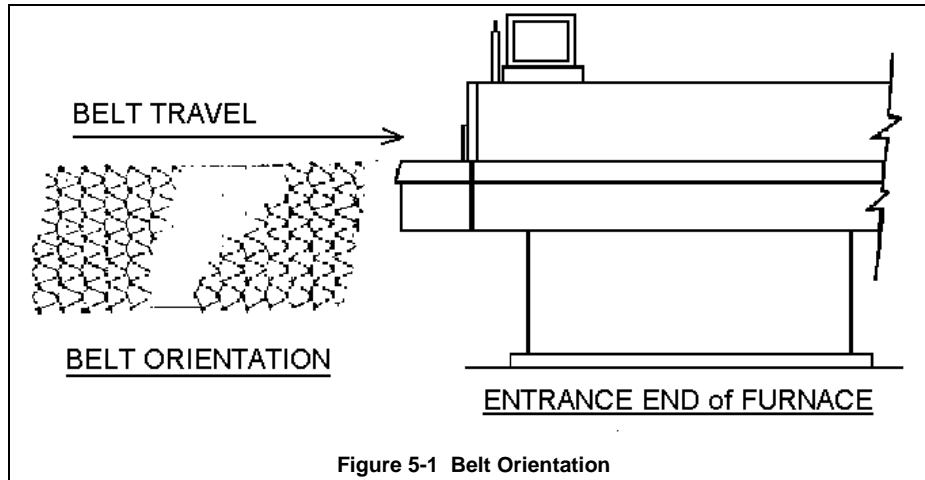

Figure 4-1 Belt Path

5.0 New Belt

5.1 Orientation

5.1.1 Place the new belt roll at the entrance end of the furnace and orient as shown in the figure below. Note the weave pattern. Orient belt with the top of the triangles pointing in the direction of travel.



5.2 Installation

5.2.1 Extend a long rod or stick through the furnace chamber, being careful not to damage the lamps or insulation. If possible, use the old belt to draw a pull wire through the chamber during its removal.

5.2.2 Securely attach the leading edge of the belt to the rod. Carefully pull the belt through the furnace from the exit end, while an assistant at the entrance unrolls and guides the belt into the furnace.

5.2.3 When the belt has been pulled through the furnace chamber, remove the rod and thread a pull wire through the rollers and drive drum, as shown below.

5.3 Splice the Belt

5.3.1 Line up the ends of the belt so they are parallel and slightly overlapping.

5.3.2 Splice the belt by inserting one of the cross-section wires through the belt mesh across the width of the belt as shown in the figure.

5.3.3 The wire should be even and parallel and aligned with the belt edges. The cross-section wire will stay in place without any finishing at either end.

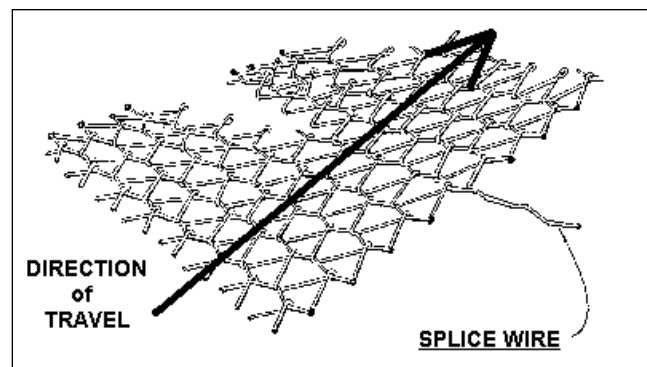

5.4 Final Steps

5.4.1 Replace Belt weight. lower into belt weight enclosure to tension weight.

5.4.2 Open facility process gas valve to tension belt. Check pressure gauge at reservoir to assure it reads 15 psi (see figure 3-1). The system will hold this pressure for a number days or longer even when gas is turned off.

5.4.3 Turn on furnace power.