

Transport Drive Inverter HF-320 α Series

Sensorless Vector Inverter



INVERTER HF-320 α

For all our customers' easy use,

we made our inverter even more compact, easy maintenance, and reduced noise.

Now, you have easier access to high-function and high-performance!

We actualized optimal startup and acceleration by building-in new current vector computation and Sumitomo Motor constant in the standard type.

This inverter is ideal for our gearmotor operation.



■ Nomenclature example

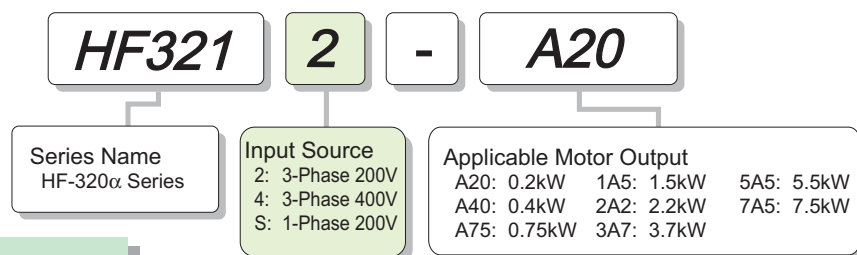

Easy Access to High Performance !

- High Torque
- Built-in Noise Filter
- Easy-Maintenance and Long Lifetime
- Compact



Corresponds to major standards of the world

Specifications

Item		Specification									
Input Voltage Class		3-Phase 200V									
Motor HP (kW)		0.25 (0.2)	0.5 (0.4)	1 (0.75)	2 (1.5)	3 (2.2)	5 (3.7)	7.5 (5.5)	10 (7.5)	15 (11)	20 (15)
Rating	Type	HF3212-									
	Motor Output	A20	A40	A75	1A5	2A2	3A7	5A5	7A5	011	015
	Capacity (kVA) ^[1]	0.6	1.3	1.8	3.1	4.2	6.7	10	13	21	25
	Rated Output Current (A) ^[2]	1.6 (1.5)	3.3 (3.3)	5 (4.4)	8 (7.9)	11 (10)	17.5 (16.4)	27.5 (25)	33 (33)	54 (49)	66 (60)
	Output Voltage ^[3]	3-phase 200V to 240V									
	Overload Current Rating	150% - 60 seconds, 200% - 0.5 seconds									
	Voltage Frequency	3-phase 200V to 240V - 50/60 Hz									
Power Supply	Allowable Fluctuation	Voltage +10%, -15% ^[4] , frequency \pm 5%									
	Protective Method	IP20 enclosed type (JEM1030)									
Cooling Method		Self-cooling				Forced air-cooled					
Color		Munsell 5Y-8/0.5									
Built-in Filter		RFI filter ^[5]									
Environment	Atmosphere	Indoors; maximum altitude: 3,280.84 ft. (1000 m); not exposed to direct sunlight, corrosive or explosive gas, vibration (less than 5.9m/s ²) (10 to 55Hz)									
	Ambient Temperature	-10°C to +50°C (above 40°C, remove the protective seal from the top of the inverter)									
	Storage Temperature	-20°C to +65°C									
	Relative Humidity	20 to 93% (condensation free)									

Dimensions

Input Voltage	Motor HP (kW)	Inverter Type	Figure	Dimensions (mm)						Approx. Weight (kg)
				W	H	D	W1	H1	H2	
3-phase 200V	0.25 (0.2)	HF3212-A20	A	72	130	120	60	121.5	15	1.1
	0.5 (0.4)	HF3212-A40				1.2				
	1 (0.75)	HF3212-A75				1.2				
	2 (1.5)	HF3212-1A5	B	105	130	130	93	121.5	13	1.4
	3 (2.2)	HF3212-2A2				150				2.3
	5 (3.7)	HF3212-3A7	C	140	170	150	126	157	14	2.5
	7.5 (5.5)	HF3212-5A5	D	180	220	170	160	210	19.2	6.2
	10 (7.5)	HF3212-7A5								6.3
	15 (11)	HF3212-011	D*	245	310	190	225	295	19.5	9.8
20 (15)	HF3212-015	9.9								

Notes:

- [1] Capacity is calculated at 220V for the 200V class and at 440V for the 400V class.
- [2] Indicates rated output current setting when the PWM carrier frequency (parameter F300) is 4kHz or less. When exceeding 4kHz, the rated output current setting is shown in parentheses. When the input power voltage of the 400V class model exceeds 480V, it is necessary to further reduce the setting. The default setting of the PWM carrier frequency is 12 kHz.
- [3] Maximum output voltage is the same as the input voltage.
- [4] \pm 10% when the inverter is used continuously (load of 100%).
- [5] Built-in standard filter: Core and capacitors; With RFI noise filter option: complies EN55011 Class A Group 1 (Max. length of motor connecting cable 16.40 ft. or 5m) and Class B Group 1 (Max. length of motor connecting cable 3.28 ft. or 1m).
- [6] In high-attenuation EMI filter: Complies EN55011 Class A Group 1 (Max. length of motor connecting cable 16.40 ft. or 5m); With RFI noise filter option: complies EN55011 Class B Group 1 (Max. length of motor connecting cable 65.62 ft. or 20m) and Class A Group 1 (Max. length of motor connecting cable 164.04 FT OR 50 m).

Explanation of Function

■ Sound Basic Functions

- With keypad and the frequency setting potentiometer on the front panel, you can start operation easily and immediately.
- Every model has a regenerative braking circuit built-in, so only an optional braking resistor needs to be connected if required.
- All three-phase and single-phase 200V models with a capacity of 0.75kW or less are capable of self-cooling without needing fans.

■ Completely Noise-Proof

- An optional EMC plate can also be attached with a built-in noise filter. This facilitates the wiring of shielded cables to ground, and to the machine ground.
- If leakage current is a problem, disconnecting the grounding capacitor can reduce it by simply pulling up a jumper switch (Single-phase 200V and three-phase 400V models).

■ A Wide Variety of Input Terminal Functions

- Two analog input terminals can be used as logic input terminals by changing parameter settings.
- If the two analog input terminals are switched over to logic input terminals, up to eight contact input terminals can be used at a same time.
- A function can be selected from among 65 functions and assigned to each individual contact input terminal.
- With a slide switch, you can easily switch between sink logic and source logic configurations.
- Power can be supplied from either the internal power supply (24V) but also an external power supply (optional). In the latter case, power is supplied through the PCS terminals.

■ A Great Variety of Output Terminals

- Three output terminals are provided: a relay contact output terminal (1c), a relay contact terminal (1a) and an open collector output terminal.
- The open collector output terminal (DRV-OM) completely insulated from other terminals, which can also be used as a pulse train output terminal.
- A function can be selected from 58 functions and assigned to each individual output terminal. It is also possible to assign two different functions to a single output terminal, economizing on the use of terminals and cables.
- Analog output terminals can be set for 0-10V, 0-1mA or 4-20mA.

■ Easy Selection and Installation

- Compact inverters with a wide range of capacities (0.2kW to 15kW) are available.
- Supporting a wide range of supply voltages:
240V class: 200V to 240V
500V class: 380V to 500V
Allowable fluctuations in voltage: +10%, -15%
- Operative in a wide range of ambient temperatures: -10°C to +60°C (When the ambient temperature is 50°C and over, the current needs to be reduced.)

■ Dynamic Functions

- A dynamic energy saving mode specially designed for fan motors provides substantial energy saving compared to conventional modes.
- The energy saving effect can be checked easily by monitoring integrated input and output kWh, in addition instantaneous power.
- A dynamic quick deceleration control mode was added to conventional deceleration modes achieving faster stopping without using a braking resistor.

■ A Wide Choice of Monitor Menu Items

- A list of up to 20 parameters, including load current and torque current, can be monitored during normal operation.
- Even if the inverter is tripped, monitoring of up to parameters can continue until power is turned off. When power is turned off, the last 10 parameters monitored at the occurrence of the last four trips are retained.
- Up to 16 kinds of monitor menu items and up to 4 kinds of outputs for adjustments can be assigned to the analog terminals and the pulse train output terminals. Also, adjustments can be made easily.
- A free-unit scaling function is provided so that various items, such as the rotational speed and the line speed, can also be displayed in addition to the operation frequency. Also, a bias can be specified.

■ Making Complicated Settings Easily

- With the automatic torque boost function, the motor can be tuned easily for vector control. (The rated current, no-load current and rated rotational speed of the motor need to be set manually.)
- With the automatic acceleration/deceleration function, the time can be set easily.
- With the automatic setting function, can be assigned easily to input terminals on the terminal board.
- With the history function, a parameter that is used repeatedly can be invoked and changed in one operation.
- Every HF-320 α inverter allows you to specify steps in which a value changes each time a button on the operation panel is pressed. For example, if you want to set the frequency by steps of 10 Hz, this feature comes in very handy.

■ Complete with Protective Functions

- All possible protective functions are provided to protect the inverter and its peripheral devices.
- More than 30 kinds of information about causes of tripping and more than 20 kinds of alarm information can be displayed.
- Every HF-320 α inverter has the function of protecting from input/output open-phases detecting the breakage of analog signal cables, and protecting from overcurrent, overvoltage and overload.

■ Programmable for a Variety of Operations

- A PID control function is provided for every HF-320 α series, control devices are not required for PID control. It is also possible to specify a control waiting time and to put out command matching signals.
- Up to three different acceleration/deceleration times can be set, so that the HF-320 α can be put to a wide range of uses.
- A motor setting can be selected between two. It is possible to select a base frequency, a voltage, an amount of torque boost, a thermal protection level, a stall operation level, a V/F pattern, and so on.
- The output frequency can be set within a range of up to 500Hz.

■ Complete with Communications Functions

- Terminal circuit boards are detachable and replaceable with a large variety of optional circuit boards.
- An RS485 communications circuit board is optionally available. It also supports Modbus RTU protocol.
- Optional software program enables you to set parameters using a personal computer, you can easily check, read, edit, write and save parameter settings.
- Using the block reading/writing function that was newly added to communications functions, you can issue a command or monitor the operating conditions more easily and more quickly.
- Communications circuit boards supporting DeviceNET, LonWorks, and so on are on the drawing board.

■ Selecting the Capacity (Model) of the Inverter Selection

● Capacity

Refer to the applicable motor capacities listed in the standard specifications.

When driving a high-pole motor, special motor, or multiple motors in parallel, select such an inverter that the sum of the motor rated current multiplied by 1.05 to 1.1 is less than the inverter's rated output current value.

● Acceleration/Deceleration Times

The actual acceleration and deceleration times of a motor driven by an inverter are determined by the torque and moment of inertia 2 of the load, and can be calculated by the following equations.

The acceleration and deceleration times of an inverter can be set individually. In any case, however, they should be set longer than their respective values determined by the following equations.

Acceleration time	$t_a = \frac{(J_M + J_L) \times \Delta N}{9.56 \times (T_M + T_L)} \quad (\text{sec})$
Deceleration time	$t_a = \frac{(J_M + J_L) \times \Delta N}{9.56 \times (T_B + T_L)} \quad (\text{sec})$
Conditions	<p>J_M: Moment of inertia of motor (kg·m²)</p> <p>J_L: Moment of inertia of load (kg·m²) (converted into value on motor shaft)</p> <p>ΔN: Difference in rotating speed between before and after acceleration or deceleration (min⁻¹)</p> <p>T_L: Load torque (N·m)</p> <p>T_M: Motor rated torque x 1.2-1.3 (N·m) [V/f control] Motor rated torque x 1.5 (N·m) [Vector operation control]</p> <p>T_B: Motor rated torque x 0.2 (N·m) When a braking resistor or a braking resistor unit is used: Motor rated torque x 0.8-1.0 (N·m)</p>

● Allowable Torque Characteristics

When a standard motor is combined with an inverter to perform variable speed operation, the motor temperature rises slightly higher than it normally does during commercial power supply operation. This is because the inverter output voltage has a sinusoidal (approximate) PWM waveform. In addition, the cooling becomes less effective at low speed, so the torque must be reduced according to the frequency.

When constant-torque operation must be performed at low speeds, use an AF motor designed specifically for use with inverters.

[An example of V/f control at a base frequency of 60 Hz]

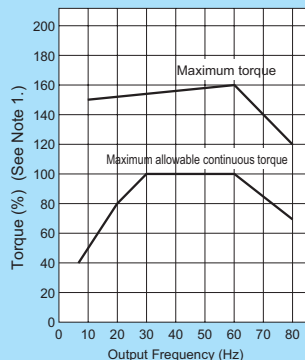

Note 1. 100% of torque refers to the amount of torque that the motor produces when it is running at a 60Hz-synchronized speed. The starting torque is smaller in this case than that required when power is supplied from a commercial power line. So, the characteristics of the machine to be operated need to be taken into consideration.

Note 2. The maximum allowable torque at 50Hz can be calculated approximately by multiplying the maximum allowable torque at a base frequency of 60Hz by 0.8.

● Starting Characteristics

When a motor is driven by an inverter, its operation is restricted by the inverter's overload current rating, so the starting characteristic is different from those obtained from commercial power supply operation.

Although the starting torque is smaller with an inverter than with the commercial power supply, a high starting torque can be produced at low speeds by adjusting the V/f pattern torque boost amount or by employing vector control. (200% in sensorless control mode, though this rate varies with the motor characteristics). When a larger starting torque is necessary, select an inverter with a larger capacity and examine the possibility of increasing the motor capacity.

■ Harmonic Current and Influence to Power Supply

● Harmonics are defined as sinusoidal waves that is multiple frequency of commercial power (base frequency: 50Hz or 60Hz). Commercial power including harmonics has a distorted waveform.

Some electrical and electronic devices produce distorted waves in their rectifying and smoothing circuits on the input side. Harmonics produced by a device influence other electrical equipment and facilities in some cases (for example, overheating of phase advancing capacitors and reactors).

■ Measures for Suppressing Higher Harmonics when Driving with Inverter

● Connecting a Reactor

Harmonic current leakage from the inverter may be suppressed by connecting an input AC reactor (ACL) to the input side of the inverter or DC reactor (DCL) to the DC section of the inverter.

1. Input AC Reactor (ACL)

Used to improve the input power factor, reduce the harmonics, and suppress external surge on the inverter power source side.

2. DC Reactor (DCL)

DC reactor is more efficient on improving power factor for inverter power source side. Use input AC reactor together, for suppressing external surges.

Note: Refer to section on Peripheral Equipments, or Options for measures on high frequency noise when using inverters.

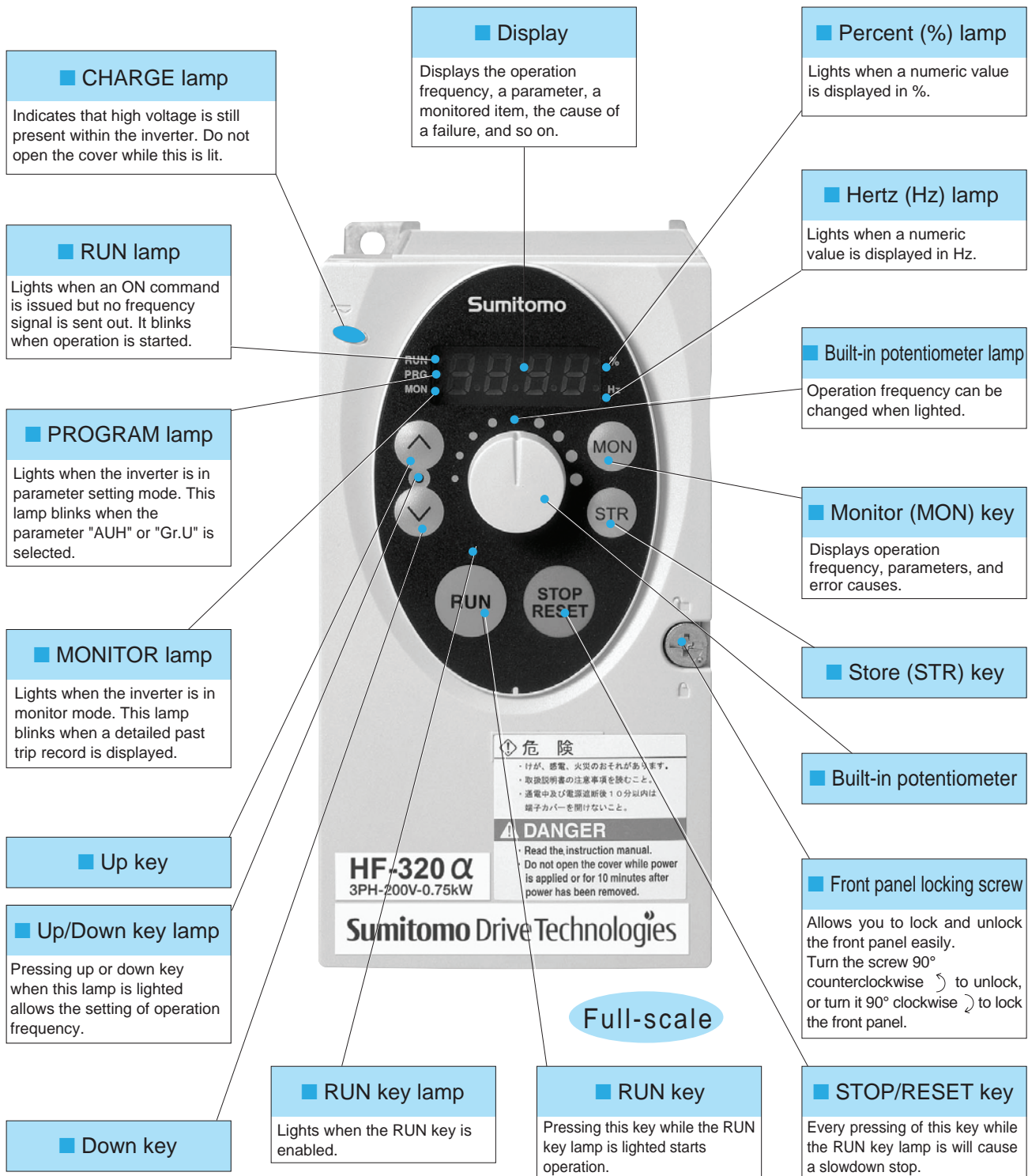

Operation

■ Explanation of Operation Panel



■ How to Start and Stop

[Example of a CnD setting procedure]

	00	Displays the operation frequency (operation stopped). (When standard monitor display selection $F7 \text{ iD}=\text{0}$ [Operation frequency])
(MON)	RHH	Displays the first basic parameter [History (RHH)].
	CnD	Press either the Δ or ∇ key to select " CnD ".
(STR)	i	Press STR key to display the parameter setting. (Default setting: i).
	0	Change the parameter to 0 (terminal board) by pressing the ∇ key.
(STR)	$\text{0} \leftrightarrow \text{CnD}$	Press the STR key to save the changed parameter. CnD and the parameter set value are displayed alternately.

■ Start and Stop Using the Operation Panel Keys ($\text{CnD}=\text{i}$)



Use the (RUN) and (STOP/RESET) keys on the operation panel to start and stop the motor.

(RUN) : Motor starts.

(STOP/RESET) : Motor stops.

■ How to Set the Frequency

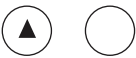
[Example of a FnD setting procedure]

	00	Displays the operation frequency (operation stopped). (When standard monitor display selection $F7 \text{ iD}=\text{0}$ [Operation frequency])
(MON)	RHH	Displays the first basic parameter [History (RHH)].
	FnD	Press either the Δ or ∇ key to select " FnD ".
(STR)	0	Press STR key to display the parameter setting. (Default setting: 0).
	3	Change the parameter to 3 (terminal board) by pressing the ∇ key.
(STR)	$\text{3} \leftrightarrow \text{FnD}$	Press the STR key to save the changed parameter. FnD and the parameter set value are displayed alternately.

*Pressing the MON key twice returns the display to standard monitor mode (displaying operation frequency).

■ Setting the Frequency Using the Potentiometer on the Inverter Main Unit ($\text{FnD}=\text{0}$)

Set the frequency with the notches on the potentiometer.

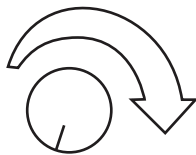

Move clockwise for the higher frequencies.

The potentiometer has hysteresis. So the set value may slightly change when the inverter is turned off, and then turned back on.

Standard Specifications

■ 3-phase 200V

Item		Specification							
Input voltage class		3-phase 200V							
Applicable motor (kW)		0.2	0.4	0.75	1.5	2.2	3.7	5.5	7.5
Rating	Type Form	HF3212-							
	Capacity (kVA) ^{Note 1}	A20	A40	A75	1A5	2A2	3A7	5A5	7A5
	Rated output current (A) ^{Note 2}	0.6	1.3	1.8	3.1	4.2	6.7	10	13
	Rated output current (A) ^{Note 2}	1.6	3.3	4.8	8.0	11.0	17.5	27.5	33
	Output voltage ^{Note 3}	(1.5)	(3.3)	(4.4)	(7.9)	(10.0)	(16.4)	(25.0)	(33)
	Overload current rating	3-phase 200V to 240V							
Power supply	Overload current rating	150%-60 seconds, 200%-0.5 second							
	Voltage-frequency	3-phase 200V to 240V - 50/60Hz							
	Allowable fluctuation	Voltage + 10%, -15% ^{Note 4} , frequency ±5%							
	Protective method	IP20 Enclosed type (JEM1030)							
	Cooling method	Self-cooling			Forced air-cooled				
	Color	Munsel 5Y-8/0.5							
Built-in filter		Basic filter ^{Note 5}							

■ 3-phase 400V

Item		Specification						
Input voltage class		3-phase 400V						
Applicable motor (kW)		0.4	0.75	1.5	2.2	4.0	5.5	7.5
Rating	Type Form	HF3214-						
	Capacity (kVA) ^{Note 1}	A40	A75	1A5	2A2	3A7	5A5	7A5
	Rated output current (A) ^{Note 2}	1.1	1.8	3.1	4.2	7.2	11	13
	Rated output current (A) ^{Note 2}	1.5	2.5	4.1	5.5	9.5	14.3	17
	Output voltage ^{Note 3}	(1.5)	(2.1)	(3.7)	(5.0)	(8.6)	(13.0)	(17)
	Overload current rating	3-phase 380V to 500V						
Power supply	Overload current rating	150%-60 seconds, 200%-0.5 second						
	Voltage-frequency	3-phase 380V to 500V - 50/60Hz						
	Allowable fluctuation	Voltage + 10%, -15% ^{Note 4} , frequency ±5%						
	Protective method	IP20 Enclosed type (JEM1030)						
	Cooling method	Forced air-cooled						
	Color	Munsel 5Y-8/0.5						
Built-in filter		High-attenuation EMI filter ^{Note 6}						

■ 1-phase 200V

Item		Specification				
Input voltage class		1-phase 200V				
Applicable motor (kW)		0.2	0.4	0.75	1.5	2.2
Rating	Type Form	HF321S-				
	Capacity (kVA) ^{Note 1}	A20	A40	A75	1A5	2A2
	Rated output current (A) ^{Note 2}	0.6	1.3	1.8	3.1	4.2
	Rated output current (A) ^{Note 2}	1.5	3.3	4.8	8.0	11.0
	Output voltage ^{Note 3}	(1.5)	(3.3)	(4.4)	(7.9)	(10.0)
	Overload current rating	3-phase 200V to 240V				
Power supply	Overload current rating	150%-60 seconds, 200%-0.5 second				
	Voltage-frequency	3-phase 200V to 240V - 50/60Hz				
	Allowable fluctuation	Voltage + 10%, -15% ^{Note 4} , frequency ±5%				
	Protective method	IP20 Enclosed type (JEM1030)				
	Cooling method	Self-cooling		Forced air-cooled		
	Color	Munsel 5Y-8/0.5				
Built-in filter		High-attenuation EMI filter ^{Note 6}				

Note 1. Capacity is calculated at 220V for the 200V class and at 440V for the 400V class.

Note 2. Indicates rated output current setting when the PWM carrier frequency (parameter F300) is 4kHz or less. When exceeding 4kHz, the rated output current setting is indicated in the parenthesis. When the input power voltage of the 400V class model exceeds 480V, it is necessary to further reduce the setting. The default setting of the PWM carrier Frequency is 12kHz.

Note 3. Maximum output voltage is the same as the input voltage.

Note 4. ±10% when the inverter is used continuously (load of 100%).

Note 5. Built-in standard filter: Core and capacities
With RFI noise filter option: Complies EN55011 Class A Group 1(Max.5m*) and Class B Group 1(Max.1m*)
*Length of motor connecting cable.

Note 6. Built-in high-attenuation EMI filter:
Complies EN55011 Class A Group 1(Max.5m*)
With RFI noise filter option: Complies EN55011 Class B Group 1(Max.20m*) and Class A Group 1(Max.50m*)
*Length of motor connecting cable.

Common Specification

Item	Specification		
Principal control functions	Control system	Sinusoidal PWM control	
	Rated output voltage	Adjustable within the range of 50 to 600V by correcting the supply voltage (not adjustable above the input voltage)	
	Output frequency range	0.5 to 500.0Hz, default setting: 0.5 to 80Hz, maximum frequency: 30 to 500Hz	
	Minimum setting steps of frequency	0.1Hz: operation panel setting, 0.2Hz: analog input (when the max. frequency is 100Hz).	
	Frequency accuracy	Digital setting: within $\pm 0.01\%$ of the max. frequency (-10 to +60°C) Analog setting: within $\pm 0.5\%$ of the max. frequency (25 C $\pm 10^\circ\text{C}$)	
	Voltage/frequency characteristics	V/f constant, variable torque, automatic torque boost, vector control, automatic energy-saving, dynamic automatic energy-saving control. Auto-tuning. Base frequency (25 - 500Hz) adjusting to 1 or 2, torque boost (0 - 30%) adjusting to 1 or 2, adjusting frequency at start (0.5 - 10Hz)	
	Frequency setting signal	Potentiometer on the front panel, external frequency potentiometer (connectable to a potentiometer with a rated impedance of 1 - 10k Ω), 0 - 10Vdc (input impedance: VRF/VRF2=30k Ω), 4 - 20mAdc (Input impedance: 250 Ω).	
	Terminal board base frequency	The characteristic can be set arbitrarily by two-point setting. Possible to set individually for three functions: analog input (VRF and VRF2) and communication command.	
	Frequency jump	Three frequencies can be set. Setting of the jump frequency and the range.	
	Upper- and lower-limit frequencies	Upper-limit frequency: 0 to max. frequency, lower-limit frequency: 0 to upper-limit frequency	
	PWM carrier frequency	Adjustable within a range of 2.0 to 16.0Hz (default: 4kHz).	
	PID control	Setting of proportional gain, integral gain, differential gain and control wait time. Checking whether the amount of processing amount and the amount of feedback agree.	
	Operation specifications	Acceleration/deceleration time	Selectable from among acceleration/deceleration times 1, 2 or 3 (0.0 to 3200 sec.). Automatic acceleration/deceleration function. S-pattern 1 or 2, and S-pattern value adjustable. Forced rapid deceleration and dynamic rapid deceleration function.
		DC braking	Braking start-up frequency: 0 to maximum frequency, braking rate: 0 to 100%, braking time: 0 to 20 seconds, emergency DC braking, motor shaft fixing control
Dynamic braking		Control and drive circuit is built in the inverter with the braking resistor outside (optional).	
Input terminal function (programmable)		Possible to select from among 65 functions, such as forward/reverse run signal input, jog run signal input, operation base signal input and reset signal input, to assign to 8 input terminals. Logic selectable between sink and source.	
Output terminal functions (programmable)		Possible to select from among 58 functions, such as upper/lower limit frequency signal output, low speed detection signal output, specified speed reach signal output and failure signal output, to assign to FL relay output, open collector output and RY output terminals.	
Forward/reverse run		The RUN and STOP/RESET keys on the operation panel are used to start and stop operation, respectively. The switching between forward run and reverse run can be done from one of the three control units: operation panel, terminal board and external control unit.	
Jog run		Jog mode, if selected, allows jog operation from the operation panel or the terminal board.	
Preset speed operation		Base frequency + 15-speed operation possible by changing the combination of 4 contacts on the terminal board.	
Retry operation		Capable of restarting automatically after a check of the main circuit elements in case the protective function is activated. 10 times (Max.) (selectable with a parameter)	
Various prohibition settings		Possible to write-protect parameters and to prohibit the change of panel frequency settings and the use of operation panel for operation, emergency stop or resetting.	
Regenerative power ride-through control		Possible to keep the motor running using its regenerative energy in case of a momentary power failure. (Default: OFF)	
Auto-restart operation		In the event of a momentary power failure, the inverter reads the rotational speed of the coasting motor and outputs a frequency appropriate to the rotational speed in order to restart the motor smoothly. This function can also be used when switching to commercial power.	
Drooping function		When two or more inverters are used to operate a single load, this function prevents load from concentrating on one inverter due to unbalance.	
Override function		The sum of two analog signals (VRF/VRF2) can be used as a frequency command value.	
Protective function	Failure detection signal	1c-contact output: (250Vac-0.5A-cos $\phi = 0.4$)	
	Protective function	Stall prevention, current limitation, over-current, output short circuit, over-voltage, over-voltage limitation, undervoltage, ground fault, power supply phase failure, output phase failure, overload protection by electronic thermal function, armature over-current at start-up, load side over-current at start-up, over-torque, undercurrent, overheating, cumulative operation time, life alarm, emergency stop, braking resistor over-current/overload, various pre-alarms	
	Electronic thermal characteristic	Switching between standard motor and constant-torque AF motor, switching between motors 1 and 2, setting of overload trip time, adjustment of stall prevention levels 1 and 2, selection of overload stall	
	Reset function	Function of resetting by closing contact 1a or by turning off power or the operation panel. This function is also used to save and clear trip records.	
Display function	Alarms	Stall prevention, overvoltage, overload, under-voltage, setting error, retry in process, upper/lower limits	
	Causes of failures	Over-current, overvoltage, overheating, short-circuit in load, ground fault, overload on inverter, over-current through arm at start-up, over-current through load at start-up, CPU fault, EEPROM fault, RAM fault, ROM fault, communication error. (Selectable: Over-current through braking resistor/overload, emergency stop, under-voltage, low voltage, over-torque, motor overload, output open-phase)	
	Monitoring function	Operation frequency, operation frequency command, forward/reverse run, output current, voltage in DC section, output voltage, torque, torque current, load factor of inverter, integral load factor of PBR, input power, output power, information on input terminals, information on output terminals, version of CPU1, version of CPU2, version of memory, PID feedback amount, frequency command (after PID), integral input power, integral output power, rated current, causes of past trips 1 through 4, information on life alarm, cumulative operation time	
	Past trip monitoring function	Stores data on the past four trips: number of trips that occurred in succession, operation frequency, direction of rotation, load current, input voltage, output voltage, information on input terminals, information on output terminals, and cumulative operation time when each trip occurred.	
	Output for frequency meter	Analog output (1mAdc full-scale DC ammeter or 7.5Vdc full-scale DC voltmeter/rectifier type AC voltmeter, 4 to 20mA/0 to 20mA output)	
	4-digit 7-segments LED	Frequency: inverter output frequency. Alarm: stall alarm "C", overvoltage alarm "P", overload alarm "L", overheat alarm "H". Status: inverter status (frequency, cause of activation of protective function, input/output voltage, output current, etc.) and parameter settings. Free-unit display: arbitrary unit (e.g. rotating speed) corresponding to output frequency.	
Environments	Indicator	Lamps indicating the inverter status by lighting, such as RUN lamp, MON lamp, PRG lamp, % lamp, Hz lamp, frequency setting potentiometer lamp, UP/DOWN key lamp and RUN key lamp. The charge lamp indicates that the main circuit capacitors are electrically charged.	
	Use environments	Indoor, altitude: 1000m (Max.), not exposed to direct sunlight, corrosive gas, explosive gas / vibration (less than 5.9m/s ²) (10 to 55Hz)	
	Ambient temperature	-10 to +50°C <small>Note 1</small>	
	Storage temperature	-25 to +65°C	
Relative humidity	20 to 93% (free from condensation and vapor).		

Note 1 Above 40°C : Remove the protective seal from the top of the inverter

Protective Functions

Error code	Problem	Possible causes
$\overline{OL} 1$ $\overline{OC} 1P$	Overcurrent during acceleration Overcurrent flowing in element during acceleration	<ul style="list-style-type: none"> The acceleration time acc is too short. The V/F setting is improper. A restart signal is input to the rotating motor after a momentary stop, etc. A special motor (e.g. motor with a small impedance) is used.
$\overline{OC} 2$ $\overline{OC} 2P$	Overcurrent during deceleration Overcurrent flowing in element during deceleration	<ul style="list-style-type: none"> The deceleration time dec is too short.
$\overline{OC} 3$ $\overline{OC} 3P$	Overcurrent during constant speed operation Overcurrent flowing in element during operation	<ul style="list-style-type: none"> The load fluctuates abruptly. The load is in an abnormal condition.
$\overline{OC} 1P$ $\overline{OC} 2P$ $\overline{OC} 3P$	Ground fault trip Arm overcurrent at start-up (for 11 and 15 kW models only)	<ul style="list-style-type: none"> A current leaked from an output cable or the motor to ground. A main circuit elements is defective.
\overline{OCL}	Overcurrent (An overcurrent on the load side at start-up)	<ul style="list-style-type: none"> The insulation of the output main circuit or motor is defective. The motor has too small impedance. A 11 or 15 kW model was started, although a current is leaked from an output cable or the motor to ground.
\overline{OCR}	Arm overcurrent at start-up	<ul style="list-style-type: none"> A main circuit elements is defective.
* $\overline{EPH} 1$	Input phase failure	<ul style="list-style-type: none"> A phase failure occurred in the input line of the main circuit. The capacitor in the main circuit lacks capacitance.
* $\overline{EPH} 0$	Output phase failure	<ul style="list-style-type: none"> A phase failure occurred in the output line of the main circuit.
$\overline{OP} 1$	Overvoltage during acceleration	<ul style="list-style-type: none"> The input voltage fluctuates abnormally. 1. The power supply has a capacity of 200kVA or more. 2. A power factor improvement capacitor is opened or closed. 3. A system using a thyrister is connected to the same power distribution line. A restart signal is input to the rotating motor after a momentary stop, etc.
$\overline{OP} 2$	Overvoltage during deceleration	<ul style="list-style-type: none"> The deceleration time dec is too short. (Regenerative energy is too large.) $F304$ (dynamic braking resistor) is off. $F305$ (overvoltage limit operation) is off. The input voltage fluctuates abnormally. 1. The power supply has a capacity of 200kVA or more. 2. A power factor improvement capacitor is opened and closed. 3. A system using a thyrister is connected to the same power distribution line.
$\overline{OP} 3$	Overvoltage during constant-speed operation	<ul style="list-style-type: none"> The input voltage fluctuates abnormally. 1. The power supply has a capacity of 200kVA or more. 2. A power factor improvement capacitor is opened or closed. 3. A system using a thyrister is connected to the same power distribution line. The motor is in a regenerative state because the load causes the motor to run at a frequency higher than the inverter output frequency.
$\overline{OL} 1$	Inverter overload	<ul style="list-style-type: none"> The acceleration time ACC is too short. The DC braking amount is too large. The V/F setting is improper. A restart signal is input to the rotating motor after a momentary stop, etc. The load is too large.
$\overline{OL} 2$	Motor overload	<ul style="list-style-type: none"> The V/F setting is improper. The motor is locked up. Low-speed operation is performed continuously. An excessive load is applied to the motor during operation.

Error code	Problem	Possible causes
$\overline{OL} r$	Dynamic braking resistor overload trip	<ul style="list-style-type: none"> The deceleration time is too short. Dynamic braking is too large.
* \overline{OT}	Over-torque trip	<ul style="list-style-type: none"> Over-torque reaches to a detection level during operation.
\overline{OH}	Overheat	<ul style="list-style-type: none"> The cooling fan does not rotate. The ambient temperature is too high. The vent is blocked up. A heat generating device is installed close to the inverter. The thermistor in the unit is broken.
$\overline{OHT} 2$	External thermal trip	<ul style="list-style-type: none"> An external thermal trip is input.
\overline{E}	Emergency stop	<ul style="list-style-type: none"> During automatic operation or remote operation, a stop command is entered from the operation panel or a remote input device.
$\overline{EEP} 1$	EEPROM fault 1	<ul style="list-style-type: none"> A data writing error occurs.
$\overline{EEP} 2$	EEPROM fault 2	<ul style="list-style-type: none"> Power supply is cut off during typ operation and data writing is aborted.
$\overline{EEP} 3$	EEPROM fault 3	<ul style="list-style-type: none"> A data reading error occurred.
$\overline{Err} 2$	Main unit RAM fault	<ul style="list-style-type: none"> The control RAM is defective.
$\overline{Err} 3$	Main unit ROM fault	<ul style="list-style-type: none"> The control ROM is defective.
$\overline{Err} 4$	CPU fault 1	<ul style="list-style-type: none"> The control CPU is defective.
$\overline{Err} 5$	Remote control error	<ul style="list-style-type: none"> An error arises during remote operation.
$\overline{Err} 7$	Current detector fault	<ul style="list-style-type: none"> The current detector is defective.
$\overline{Err} 8$	Optional circuit board format error	<ul style="list-style-type: none"> An optional circuit board in a different format is installed.
* \overline{UL}	Low-current operation Trip	<ul style="list-style-type: none"> The output current decreased to a low-current detection level during operation.
* $\overline{UP} 1$	Undervoltage trip (main circuit)	<ul style="list-style-type: none"> The input voltage (in the main circuit) is too low.
$\overline{EF} 2$	Ground fault trip	<ul style="list-style-type: none"> A ground fault occurs in the output cable or the motor.
$\overline{Etn} 1$	Auto-tuning error	<ul style="list-style-type: none"> Check the motor parameter $F40 1$ to $F49 4$. The motor with the capacity of 2 classes or less than the inverter is used. The output cable is too thin. The motor is rotating. The inverter is used for loads other than those of three-phase induction motors.
\overline{EtYP}	Invertertype error	<ul style="list-style-type: none"> Circuit board is changed. (Or main circuit/drive circuit board)
* $\overline{E-1B}$	Brea in analog signal cable	<ul style="list-style-type: none"> The signal input via VRF is below the analog signal detection level set with $F533$.
$\overline{E-19}$	CPU communications error	<ul style="list-style-type: none"> A communications error occurs between control CPUs.
$\overline{E-20}$	Excessive torque boosted	<ul style="list-style-type: none"> The torque boost parameter vb is set too high. The motor has too small impedance.
$\overline{E-21}$	CPU fault 2	<ul style="list-style-type: none"> The control CPU is defective.

■ Main Circuit Terminal Functions

Terminals symbol	Terminal function
	Grounding terminal for connecting inverter. There are 3 terminals in total. 2 terminals in the terminal board, 1 terminal in the cooling fin.
R/L1, S/L2, T/L3	200V class: single-phase 200~240V-50/60Hz *Single-phase input: R/L1 and S/L2 terminals 3-phase 200~240V-50/60Hz 400V class: 3-phase 380~500V-50/60Hz
U/T1, V/T2, W/T3	Connect to a (three-phase induction) motor.
P(+), PR	Connect to braking resistors. Change parameters F304, F305, F309, if necessary.
N(-)	This is a negative potential terminal in the internal DC main circuit. DC common power can be input across the P(+) terminals (positive potential).
P1, P(+)	Terminals for connecting a DC reactor (DCL: optional external device). Shorted by a short bar when shipped from the factory. Before installing DCL, remove the short bar.

■ Control Circuit Terminal Functions

Terminal symbol	Function	Electrical specifications	Wire size
FR	Multifunction programmable contact input	Dry contact input 24Vdc - 5mA or less *Sink/Source/PCS selectable using SW	Solid wire : 0.3 to 1.5 (mm ²) Stranded wire : 0.3 to 1.5 (mm ²) (AWG22 to 16) Sheath strip length : 6 (mm)
RR			
RST			
DFL			
DFM			
DFH			
PCS	External 24Vdc power input	24Vdc (Insulation resistance: 50Vdc)	
COM	Control circuit's equipotential terminal (sink logic).3 common terminals for input/output.		
+V	Power output for analog input setting.	10Vdc (permissible load current: 10mAdc)	
VRF Note 1	Multifunction programmable analog input. Standard default setting: 0-10Vdc input and 0-60Hz frequency. The function can be changed to 4-20 mAdc (0-20 mA) current input by flipping the VRF slide switch to the I position.	10Vdc (internal impedance: 30kΩ) 4~20mA (Internal impedance: 250Ω)	
VRF2 Note 1	Multifunction programmable analog input. Standard default setting: 0-10Vdc input and 0-50Hz (50Hz setting) or 0-60Hz (60Hz setting) frequency.	10Vdc (internal impedance: 30kΩ)	
FRQ	Multifunction programmable analog output. Standard default setting: output frequency. Connect a 1mAdc full-scale ammeter or 7.5Vdc (10Vdc)-1mA full-scale voltmeter. The function can be changed to 0-20mAdc (4-20mA) current output by flipping the FRQ slide switch to the I position.	1mA full-scale DC ammeter or 7.5Vdc 1mA full-scale DC voltmeter 0-20mA (4-20mA) full-scale DC ammeter	Screwdriver: Small-sized flat-blade screwdriver Blade thickness: 0.4 mm or less Blade width: 2.5 mm or less
P24V	When the source logic is used, a common terminal 24Vdc is connected.	24Vdc - 100mA	
DRV OM Note 2	Multifunction programmable open collector output. Standard default settings detect and output speed reach signal output frequencies. The OM terminal is an isoelectric output terminal. It is insulated from the COM terminal. These terminals can also be used as multifunction programmable pulse train output terminals.	Open collector output: 24Vdc - 50mA Pulse train output 10mA or more	
RC RY Note 2	Multifunction programmable relay contact output. Contact ratings: 250Vac - 2A (cos = 1), 30Vdc - 1A, 250Vac - 1A (cos = 0.4). Standard default settings detect and output low-speed signal output frequencies.	250Vac - 1A: at resistance load 30Vdc - 0.5A, 250Vac - 0.5A (cosφ = 0.4)	
FA FB FC	Multifunction programmable relay contact output. Contact ratings: 250Vac-1A (cos = 1), 30Vdc-0.5A, 250Vac-0.5A (cos = 0.4). Detects the operation of the inverter's protection function. Contact across FA-FC is closed and FB-FC is opened during protection function operation.	250Vac - 1A: at resistance load 30Vdc - 0.5A, 250Vac - 0.5A (cosφ = 0.4)	

Note 1: By changing parameter setting, this terminal can also be used as a multifunction programmable contact input terminal. When the inverter is used in a sink logic configuration, a resistor (4.7k at 0.5W) should be inserted between the P24 and VRF/VRF2 terminals. Also, the slide switch for the VRF terminal needs to be turned to the V position.

Note 2: Multifunction output terminals to which two different functions can be assigned.

Standard Connection Diagram

■ Sink (Negative) Logic: Common = COM

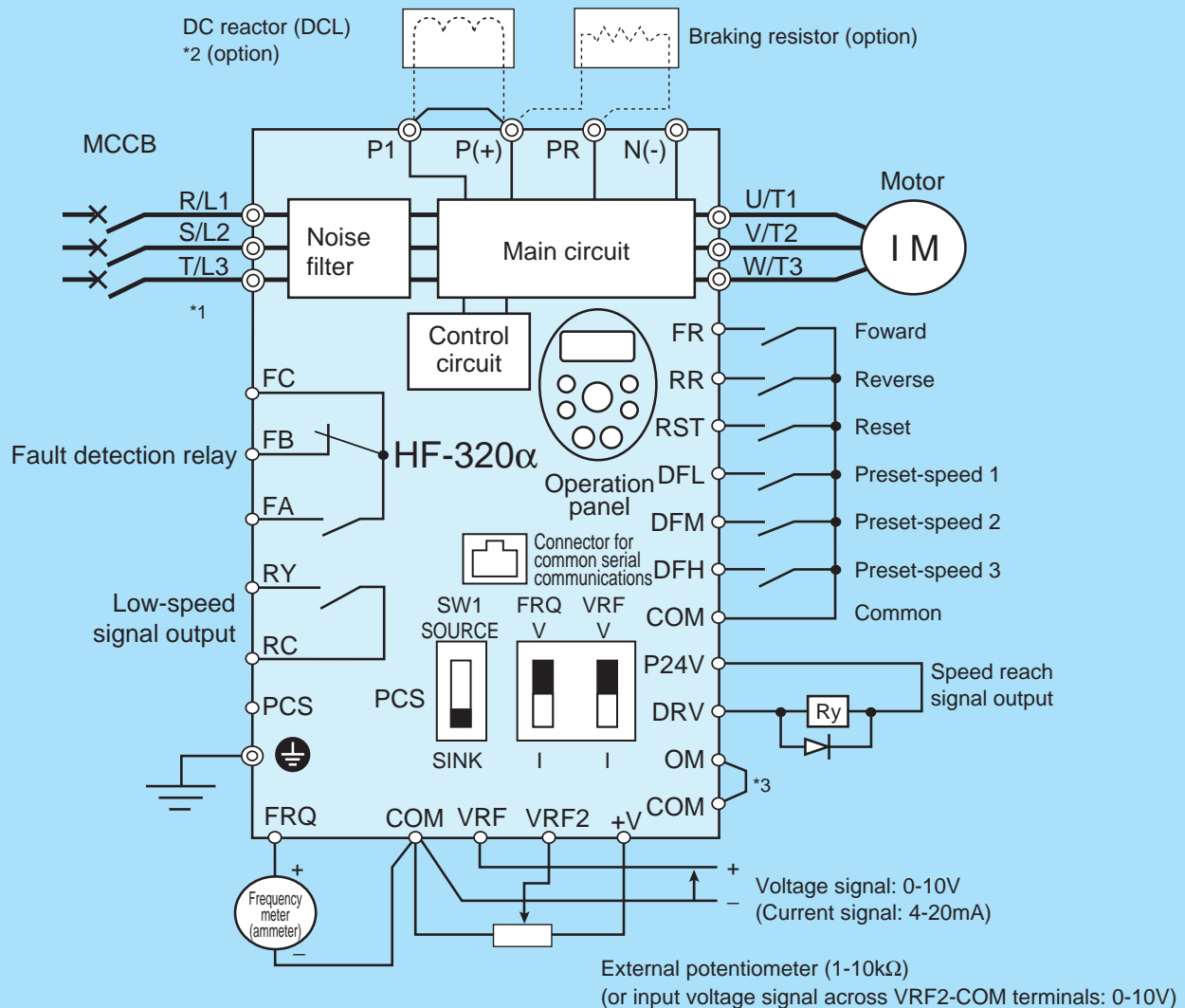

Main circuit power supply
200V class: 3-phase
200-240V -50/60Hz
400V class: 3-phase
380-500V -50/60Hz

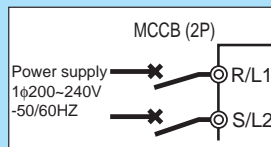

*1: The T/L3 terminal not provided for signal-phase models.
Use the R/L1 and S/L2 terminal as input terminals.

*2: The inverter came with the P1 and the P(+) terminals shorted by means of a shunting bar.
Before installing the DC reactor (DCL), remove the bar.

*3: When using the DRV output terminal in sink logic mode, short-circuit the OM and COM terminals.

Standard Connection Diagram

■ Source (Positive) Logic: Common = P24

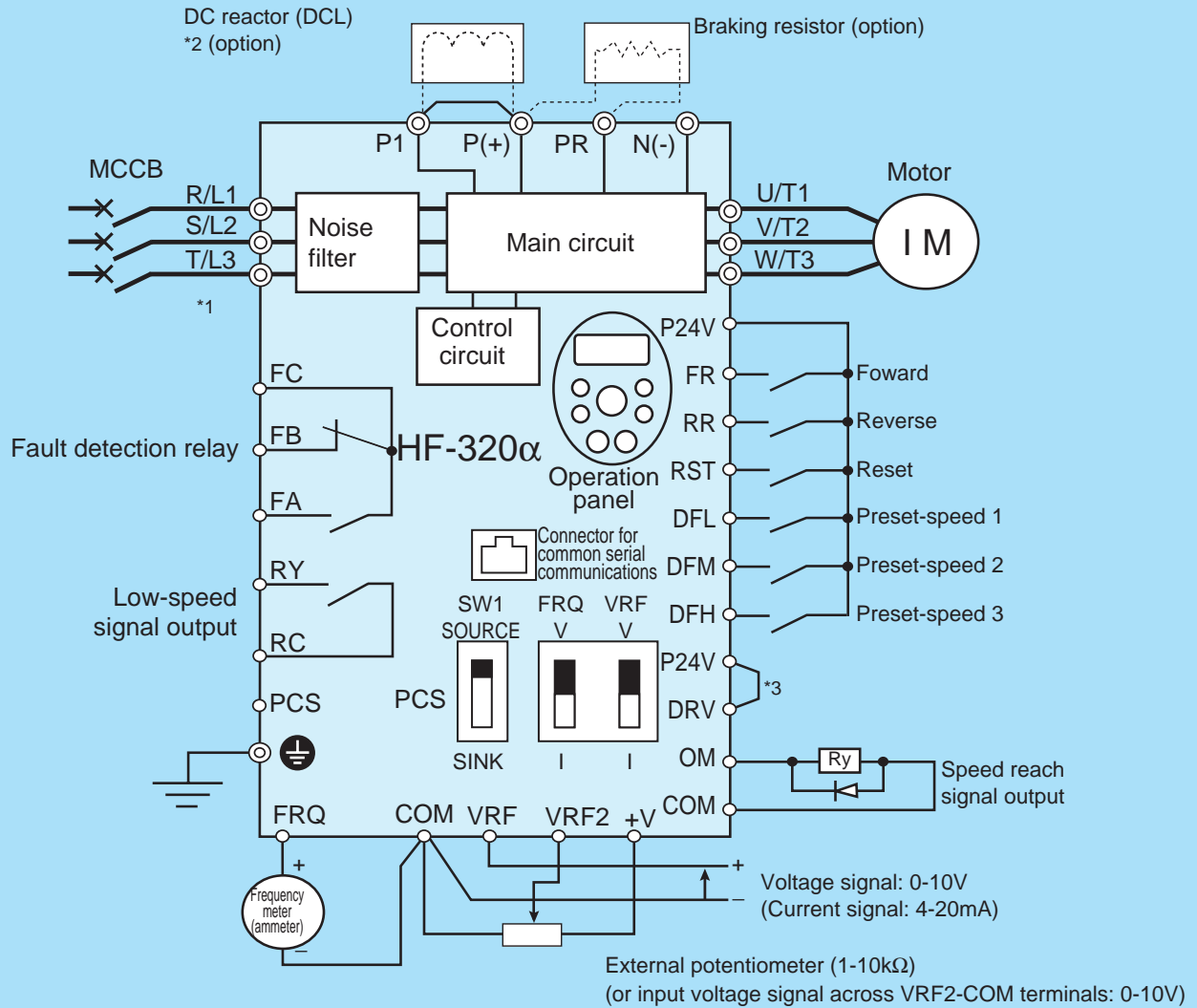

Main circuit power supply
 200V class: 3-phase
 200-240V -50/60Hz
 400V class: 3-phase
 380-500V -50/60Hz

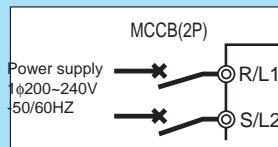

*1: The T/L3 terminal not provided for signal-phase models.
 Use the R/L1 and S/L2 terminal as input terminals.

*2: The inverter came with the P1 and the P(+) terminals shorted by means of a shorting bar.
 Before installing the DC reactor (DCL), remove the bar.

*3: When using the OM output terminal in source logic mode, short-circuit the P24V and DRV terminals.

Applied Connection Diagram

■ Operation by Current Signal (4-20 mADC)

When terminal DFL is used as a current/voltage signal (speed setting unit) changeover signal input.

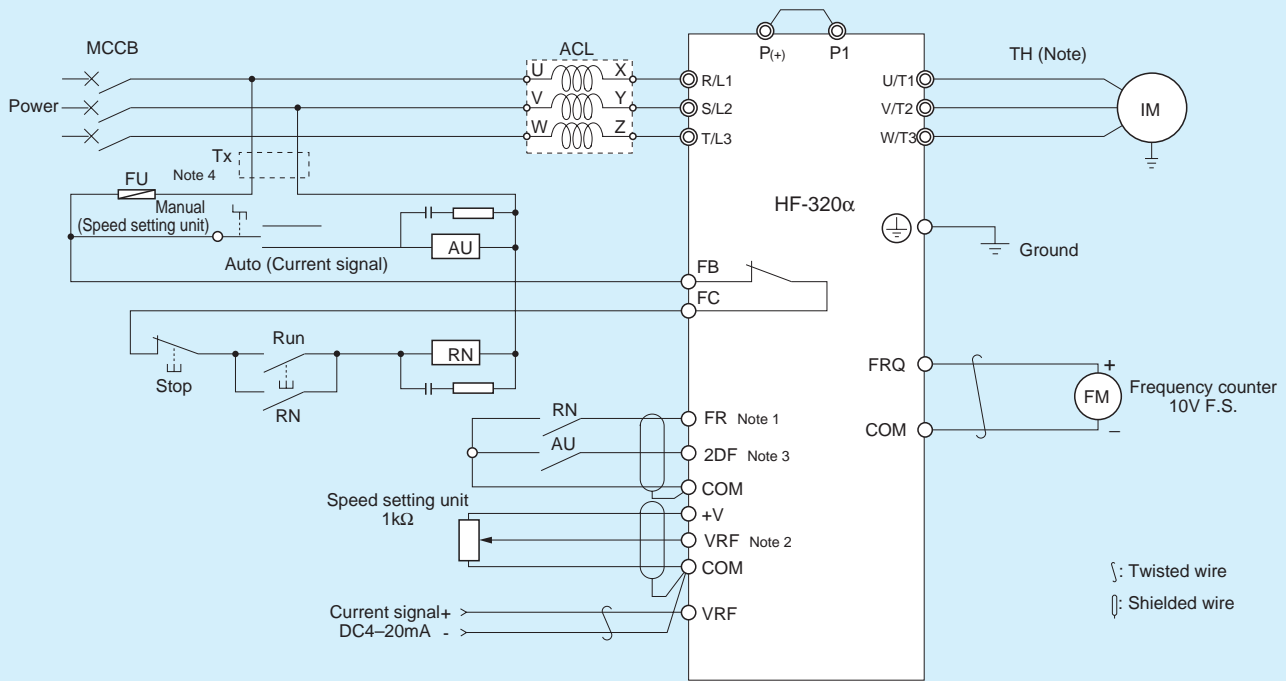

Note 1: Set parameter CMOD to "0: Terminal board"

Note 2: Set parameter FMOD to "2: VRF2." Set Parameter F201 to "1: VRF." and set switch VRF on 1 side.

Note 3: Set parameter F114 to "38: Frequency command forced switching to F207"

Note 4: Install a step-down transformer when the power is 400 V-class.

■ Multispeed Operation (16-Step Speed)

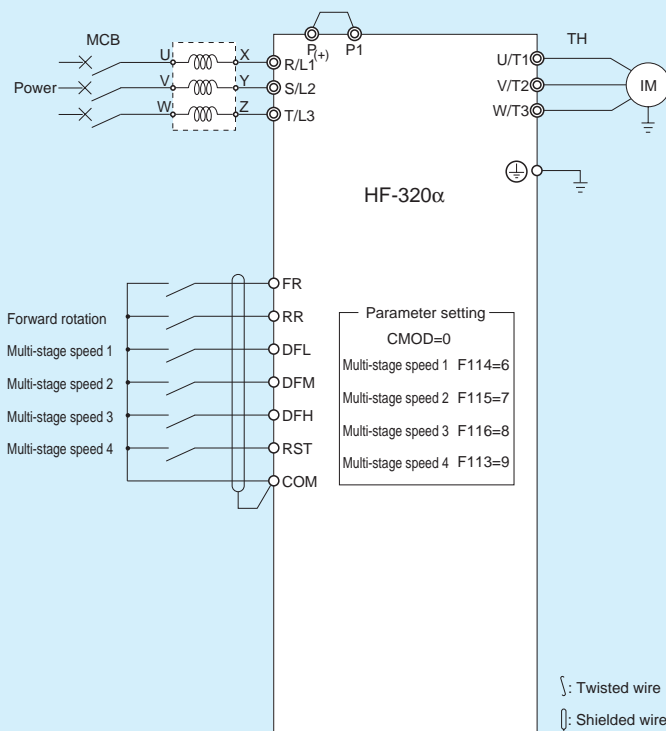

Frequency setting by external signal

Frequency setting	Multi-stage speed 1	Multi-stage speed 2	Multi-stage speed 3	Multi-stage speed 4
FC	x	x	x	x
Sr1	○	x	x	x
Sr2	x	○	x	x
Sr3	○	○	x	x
Sr4	x	x	○	x
Sr5	○	x	○	x
Sr6	x	○	○	x
Sr7	○	○	○	x
F287	x	x	x	○
F288	○	x	x	○
F289	x	○	x	○
F290	○	○	x	○
F291	x	x	○	○
F292	○	x	○	○
F293	x	○	○	○
F294	○	○	○	○

(x: Open, ○: Closed)

■ Operation of Motor with Brake

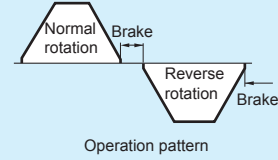
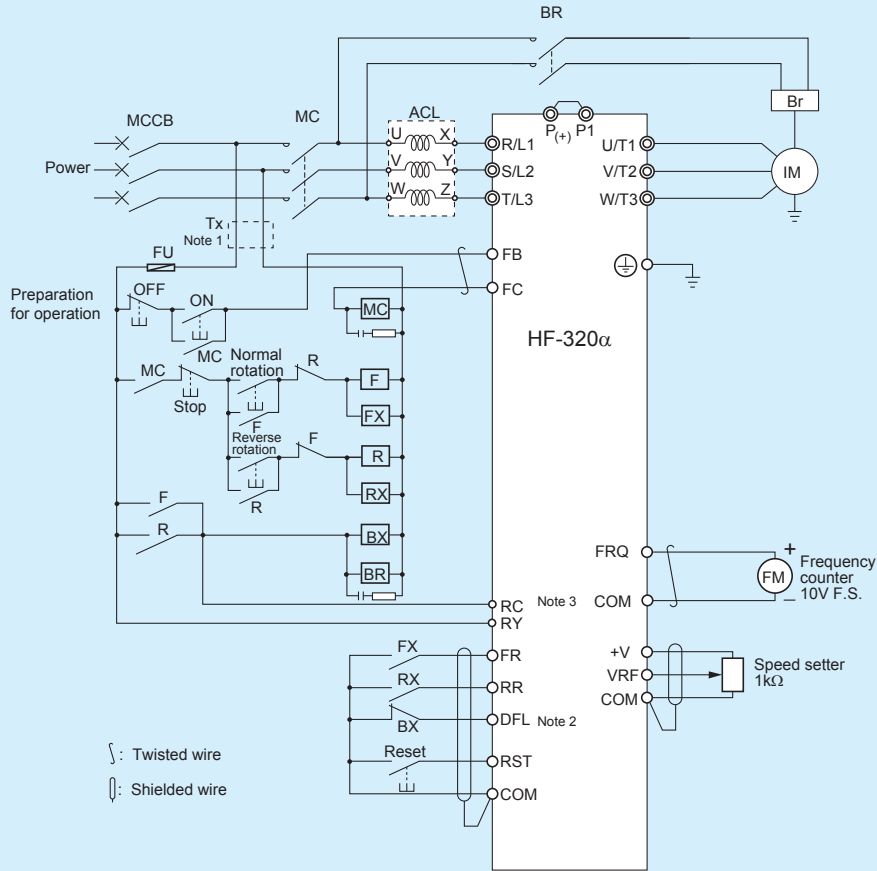

Note 1: When the power supply is a 400 V class, install a step-down transformer.

Note 2: Set parameter F114 to 54.

Note 3: Set parameter F130 to 14.

■ Up-down Operation for Positioning

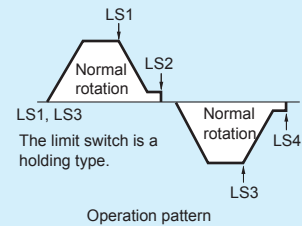
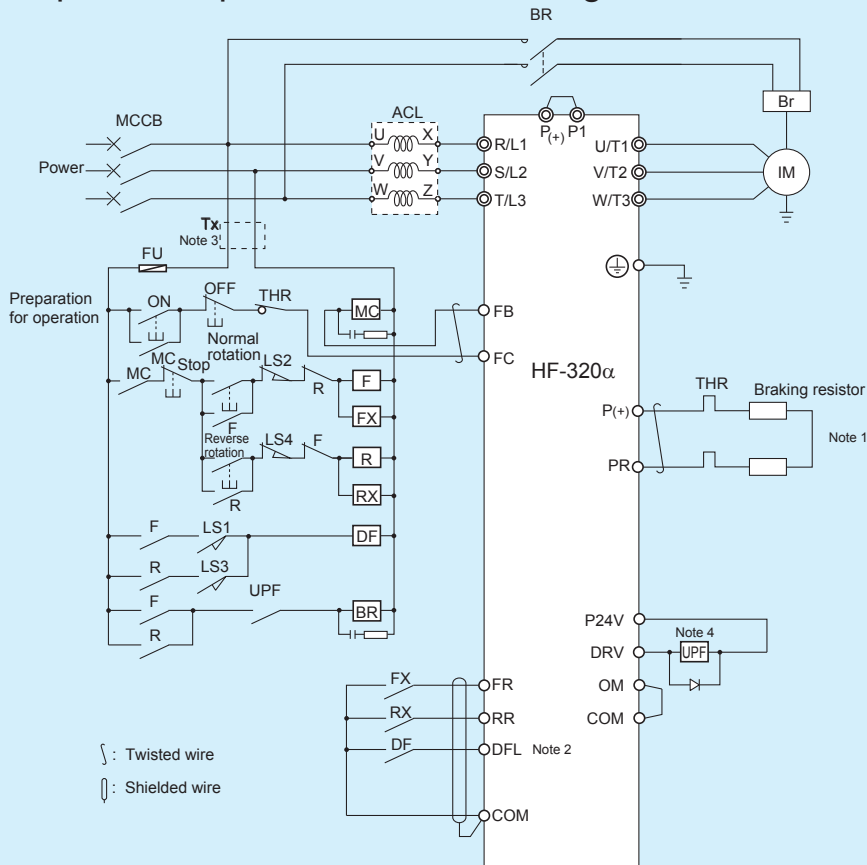

Note 1: Use inflammable cable for braking resistor wiring.

Note 2: Parameter Sr1 is for slow-speed frequency setting and FC is for high-speed setting.

Note 3: When the power supply is a 400 V class, install a step-down transformer.

Note 4: Set parameter F131 to 4 and adjust the braking timing by F100. Parameters F100 should be set at approx. 2 Hz usually.

Table of Parameters

Usage Information

*Fill in as necessary

Item	Contents	Item	Contents
Date of setting/Name		Customer name/End user name	
Combined machine/Application		Machine nomenclature/product number	
Motor manufacturer/Nomenclature		Motor capacity/Ratings	
Inverter nomenclature/quantity	HF-321-	Inverter product number/Serial number	
Usage option		Peripheral equipment used	
Used control terminal block ^{Note}	P24V, DRV, OM, FRQ, COM, FA, FB, FC, +V, VRF, VRF2, COM, PCS, DFL, DFM, DFH, FR, RR, RST, COM		
Used main circuit/Switch ^{Note}	R, S, T, U, W, E/G, P, PR, N, PI	VRF (V, I), FRQ (V, I), SW1 (SOURCE, PLC, SINK)	

Note: Circle the symbol of terminal block used.

Basic Parameters

Operational Frequency Parameter

Title	Function	Adjustment range	Default setting	Note
F ζ	Operation frequency of operation panel	LL - UL (Hz)	0.0	

4 Automatic Functions

Title	Function	Adjustment range	Default setting	Note
R ζ H	History function	Displays parameters in groups of five in the reverse order to that in which their settings were changed. (*Possible to edit)	-	
R ζ 1	Automatic acceleration/ deceleration	0: Disabled (manual) 1: Automatic 2: Automatic (only at acceleration)	0	
R ζ 2	Automatic torque boost	0: Disabled 1: Automatic torque boost + auto-tuning 2: Vector control+ auto-tuning 3: Energy saving+ auto-tuning	0	
R ζ 4	Automatic function setting	0: Disabled 1: Coast stop 2: 3-wire operation 3: External input UP/DOWN setting 4: 4-20mA current input operation	0	

Other Basic Parameters

Title	Function	Adjustment range	Default setting	Note
C ζ D	Command mode selection	0: Terminal board 1: Operation panel	1	
F ζ D	Frequency setting mode selection 1	0: Built-in potentiometer 1: VRF 2: VRF2 3: Operation panel 4: Serial communication 5: UP/DOWN from external contact 6: VRF+ VRF2 (Override)	0	

Title	Function	Adjustment range	Default setting	Note
F ζ SL	Meter selection	0: Output frequency 1: Output current 2: Set frequency 3: DC voltage 4: Output voltage command value 5: Input power 6: Output power 7: Torque 8: Torque current 9: Motor cumulative load factor 10: Inverter cumulative load factor 11: Braking resistor cumulative load factor 12: Frequency setting value (after PID) 13: VRF Input value 14: VRF2 Input value 15: Fixed output 1 (Output current: 100%) 16: Fixed output 2 (Output current: 50%) 17: Fixed output 3 (Other than the output current: 100%) 18: Serial communication data 19: For adjustments (FM set value is displayed.)	0	
F ζ	Meter adjustment	-	-	
E ζ P	Default setting	0: - 1: 50Hz default setting 2: 60Hz default setting 3: Don't choose 4: Trip record clear 5: Cumulative operation time clear 6: Initialization of type information 7: Don't choose 8: Standard default setting (Initialization) 9: Cumulative fan operation time record clear	0	
F ζ r	Forward/reverse run selection (Operation panel operation)	0: Forward run 1: Reverse run 2: Forward run (F/R switching possible) 3: Reverse run (F/R switching possible)	0	
R ζ C	Acceleration time 1	0.0-3200 (s)	10.0	
d ζ C	Deceleration time 1	0.0-3200 (s)	10.0	
F ζ H	Maximum frequency	30.0-500.0 (Hz)	60.0	
U ζ L	Upper limit frequency	0.5 - FH (Hz)	60.0	
L ζ L	Lower limit frequency	0.0 - UL (Hz)	0.0	
u ζ L	Base frequency 1	25.0-500.0 (Hz)	60.0	
u ζ u	Base frequency voltage 1	200V class: 50-330 (V) 400/600V class: 50-660 (V)	200/400	

Monitor Display

LED display on the control panel indicates numbers and alphabets as below.

LED Display (Numbers)

0	1	2	3	4	5	6	7	8	9	-
0	1	2	3	4	5	6	7	8	9	-

LED Display (Alphabet)

Aa	Bb	C	c	Dd	Ee	Ff	Gg	H	h	I	i	Jj	Kk	Ll
R	b	ç	c	d	E	F	G	H	h	i	i	j	/	L
Mm	Nn	O	o	Pp	Qq	Rr	Ss	Tt	Uu	Vv	Ww	Xx	Yy	Zz
ñ	n	ø	o	P	q	r	s	t	u	u	/	/	y	/

Table of Parameters

Title	Function	Adjustment range	Default setting	Note																							
Pt	V/F control mode selection 1	0: V/F constant 1: Variable torque 2: Automatic torque boost control 3: Sensorless Vector control 4: Automatic energy-saving 5: Dynamic automatic energy-saving (for fans and pumps) 6: Don't choose	0																								
ub	Torque boost 1	0.0 - 30.0 (%)	*1																								
EHr	Motor electronic thermal protection level 1	10 - 100 (%/A) *2	100																								
ULP	Electronic-thermal protection characteristic selection	<table border="1"> <thead> <tr> <th>Setting value</th> <th>Overload protection</th> <th>Overload stall</th> </tr> </thead> <tbody> <tr> <td>0</td> <td>Valid</td> <td>Invalid</td> </tr> <tr> <td>1</td> <td rowspan="3">Standard motor</td> <td>Valid</td> </tr> <tr> <td>2</td> <td>Invalid</td> </tr> <tr> <td>3</td> <td>Invalid</td> </tr> <tr> <td>4</td> <td rowspan="3">AF motor (inverter motor)</td> <td>Valid</td> </tr> <tr> <td>5</td> <td>Valid</td> </tr> <tr> <td>6</td> <td>Invalid</td> </tr> <tr> <td>7</td> <td>Invalid</td> <td>Valid</td> </tr> </tbody> </table>	Setting value	Overload protection	Overload stall	0	Valid	Invalid	1	Standard motor	Valid	2	Invalid	3	Invalid	4	AF motor (inverter motor)	Valid	5	Valid	6	Invalid	7	Invalid	Valid	Valid	
Setting value	Overload protection	Overload stall																									
0	Valid	Invalid																									
1	Standard motor	Valid																									
2		Invalid																									
3		Invalid																									
4	AF motor (inverter motor)	Valid																									
5		Valid																									
6		Invalid																									
7	Invalid	Valid																									
5r1	Preset-speed operation frequency 1	LL - UL (Hz)	5.0																								
5r2	Preset-speed operation frequency 2	LL - UL (Hz)	10.0																								
5r3	Preset-speed operation frequency 3	LL - UL (Hz)	15.0																								
5r4	Preset-speed operation frequency 4	LL - UL (Hz)	20.0																								
5r5	Preset-speed operation frequency 5	LL - UL (Hz)	30.0																								
5r15	Preset-speed operation frequency 6	LL - UL (Hz)	40.0																								
5r7	Preset-speed operation frequency 7	LL - UL (Hz)	50.0																								
F---	Extended parameters	-	-																								
UrU	Automatic edit function	-	-																								

Extended Parameters

Input/Output Parameters

Title	Function	Adjustment range	Default setting	Note
F100	Low-speed signal output frequency	0.0 - FH (Hz)	0.0	
F101	Speed reach setting frequency	0.0 - FH (Hz)	0.0	
F102	Speed reach detection band	0.0 - FH (Hz)	2.5	
F105	Priority selection (both FR-COM, RR-COM are ON)	0: Reverse 1: Stop	1	
F109	Analog/contact input function selection (VRF/VRF2 terminal)	0: VRF - analog input VRF2 - analog input 1: VRF - analog input VRF2 - contact input (Sink) 2: VRF - analog input VRF2 - contact input (Source) 3: VRF - contact input (Sink) VRF2 - contact input (Sink) 4: VRF - contact input (Source) VRF2 - contact input (Source)	0	
F110	Always-active function selection	0-64 (ST)	1	
F111	Input terminal selection 1 (FR)	0-64 (FR)	2	
F112	Input terminal selection 2 (RR)	0-64 (RR)	3	
F113	Input terminal selection 3 (RST)	0-64 (RST)	10	
F114	Input terminal selection 4 (DFL)	0-64 (DFL)	6	
F115	Input terminal selection 5 (DFM)	0-64 (DFM)	7	
F116	Input terminal selection 6 (DFH)	0-64 (DFH)	8	
F117	Input terminal selection 7 (VRF2)	5-17 (DFHM)	9	

*1: Default setting of the parameter differs by each inverter capacity. Refer to "Default settings by Inverter Rating" table on page 19 for actual values.

*2: Unit displayed may be selected by parameter F101 (Unit selection).

Title	Function	Adjustment range	Default setting	Note
F118	Input terminal selection 8 (VRF)	5-17 (AD2)	5	
F130	Output terminal selection 1A (RY-RC)	0-255	254	
F131	Output terminal selection 2A (DRV-OM)	0-255	14	
F132	Output terminal selection 3 (FL)	0-255	10	
F137	Output terminal selection 1B (RY-RC)	0-255	255	
F138	Output terminal selection 2B (DRV-OM)	0-255	255	
F139	Output terminal logic selection (RY-RC, DRV-OM)	0: F130 and F137, F131 and F138 1: F130 or F137, F131 and F138 2: F130 and F137, F131 or F138 3: F130 or F137, F131 or F138	0	
F167	Frequency command agreement detection range	0.0 - (Hz)	2.5	
F170	Base frequency 2	25.0-500.0 (Hz)	60.0	
F171	Base frequency voltage 2	200V class: 50-330 (V) 400V class: 50-660 (V)	200/400	
F172	Torque boost quantity 2	0.0-30.0 (%)	*1	
F173	Motor electronic-thermal protection level 2	10-100 (%/A) *2	100	
F185	Stall prevention level 2	10~199 (%/A) *2200: Disabled	150	

Frequency Parameters

Title	Function	Adjustment range	Default setting	Note
F200	Frequency priority selection	0: F100 (Switchable to F207 by the input terminal) 1: F207 (F207 for output frequencies equal to or lower than 1.0 Hz)	0	
F201	VRF input point 1 setting	0-100 (%)	0	
F202	VRF input point 1 frequency	0.0-500.0 (Hz)	0.0	
F203	VRF input point 2 setting	0-100 (%)	100	
F204	VRF input point 2 frequency	0.0-500.0 (Hz)	60.0	
F207	Frequency setting mode selection 2	0: Built-in potentiometer 1: VRF 2: VRF2 3: Serial communication 4: Serial communication 5: External contact point up-down 6: VRF + VRF2 (Override)	1	
F210	VRF2 input point 1 setting	0-100 (%)	0	
F211	VRF2 input point 1 frequency	0.0-500.0 (Hz)	0.0	
F212	VRF2 input point 2 setting	0-100 (%)	100	
F213	VRF2 input point 2 frequency	0.0-500.0 (Hz)	60.0	
F240	Starting frequency setting	0.5-10.0 (Hz)	0.5	
F241	Operation starting frequency	0.0- FH (Hz)	0.0	
F242	Operation starting frequency hysteresis	0.0- FH (Hz)	0.0	
F250	DC braking starting frequency	0.0- FH (Hz)	0.0	
F251	DC braking current	0.0-100 (%/A) *2	50	
F252	DC braking time	0.0- 20.0 (s)	1.0	
F254	Motor shaft fixing control	0: Disabled 1: Enabled	0	
F256	Auto-stop in case of lower-limit frequency continuous operation time	0.0: None 0.1~600.0 (s)	0.0	
F260	Jog run frequency	F240~20.0 (Hz)	5.0	
F261	Jog run stopping pattern	0: Slowdown stop 1: Coast stop 2: DC braking	0	
F262	Panel jog run mode	0: Disabled 1: Panel jog run mode enabled	0	

Table of Parameters

Title	Function	Adjustment range	Default setting	Note
F264	Input from external contacts - UP response time	0.0-10.0 (s)	0.1	
F265	Input from external contacts - UP frequency step width	0.0-FH (Hz)	0.1	
F266	Input from external contacts - DOWN response time	0.0-10.0 (s)	0.1	
F267	Input from external contacts - DOWN frequency step width	0.0-FH (Hz)	0.1	
F268	Initial value of UP/DOWN frequency	LL - UL (Hz)	0.0	
F269	Saving of changed value of UP/DOWN frequency	0: Not changed 1: Setting of F268 changed when power is turned off	1	
F270	Jump frequency 1	0.0- FH(Hz)	0.0	
F271	Jumping width 1	0.0-30.0 (Hz)	0.0	
F272	Jump frequency 2	0.0- FH(Hz)	0.0	
F273	Jumping width 2	0.0-30.0 (Hz)	0.0	
F274	Jump frequency 3	0.0- FH(Hz)	0.0	
F275	Jumping width 3	0.0-30.0	0.0	
F287	Preset-speed operation frequencies 8	LL - UL (Hz)	60.0	
F288	Preset-speed operation frequencies 9	LL - UL (Hz)	0.0	
F289	Preset-speed operation frequencies 10	LL - UL (Hz)	0.0	
F290	Preset-speed operation frequencies 11	LL - UL (Hz)	0.0	
F291	Preset-speed operation frequencies 12	LL - UL (Hz)	0.0	
F292	Preset-speed operation frequencies 13	LL - UL (Hz)	0.0	
F293	Preset-speed operation frequencies 14	LL - UL (Hz)	0.0	
F294	Preset-speed operation frequencies 15 (Fire-speed)	LL - UL (Hz)	0.0	

● Operation Mode Parameters

Title	Function	Adjustment range	Default setting	Note
F300	PWM carrier frequency	2.0-16.0 (kHz)	4.0	
F301	Auto-restart control selection	0: Disabled 1: At auto-restart after momentary stop 2: When turning ST-COM on or off 3: At auto-restart or when turning ST-COM on or off 4: At start-up	0	
F302	Regenerative power ride-through control /Deceleration stop	0: Disabled 1: Enabled 2: Slowdown stop	0	
F303	Retry selection (number of times)	0: None, 1-10 times	0	
F304	Dynamic braking selection	0: Dynamic braking disabled 1: Dynamic braking enabled, over-load protection enabled	0	
F305	Overvoltage limit operation (Slowdown stop mode selection)	0: Enabled 1: Prohibited 2: Enabled (forced quick deceleration) 3: Enabled (dynamic quick deceleration)	1	
F307	Supply voltage correction (output voltage limited)	0: Supply voltage uncorrected, output voltage limited 1: Supply voltage corrected, output voltage limited 2: Supply voltage uncorrected, output voltage unlimited 3: Supply voltage corrected, output voltage unlimited	3	
F308	Dynamic braking	1.0-1000 (Ω)	*1	
F309	resistance	0.01-30.00 (kW)	*1	
F311	Dynamic braking resistor capacity Reverse-run prohibition	0: Forward/reverse run permitted 1: Reverse run prohibited 2: Forward run prohibited	0	
F312	Random mode	0: Disabled, 1: Enabled	1	

Title	Function	Adjustment range	Default setting	Note
F315	Carrier frequency control mode selection	0: Carrier frequency not reduced automatically 1: Carrier frequency reduced automatically 2: Carrier frequency not reduced automatically Support for 400V models 3: Carrier frequency reduced automatically Support for 400V models.	1	
F320	Drooping gain	0-100%	0	
F323	Drooping insensitive torque band	0-100%	10	
F342	Braking mode selection	0: Disabled 1: Enabled (forward run) 2: Enabled (reverse run) 3: Enabled (operating direction)	0	
F343	Release frequency	F240-20.0 (Hz)	3.0	
F344	Release time	0.00-2.50	0.05	
F345	Creeping frequency	F240-20.0 (Hz)	3.0	
F346	Creeping time	0.00-2.50	0.10	
F359	PID control wait time	0-2400 (s)	0	
F360	PID control	0: Disabled, 1: Enabled	0	
F362	Proportional gain	0.01-100.0	0.30	
F363	Integral gain	0.01-100.0	0.20	
F366	Differential (D) gain	0.00-2.55	0.00	

● Torque Boost Parameters 1

Title	Function	Adjustment range	Default setting	Note
F400	Auto-tuning	0: Auto-tuning disabled (use of internal parameters) 1: Application of individual settings of F402 (after execution: 0) 2: Auto-tuning enabled (after execution: 0)	0	
F401	Slip frequency gain	0-150 (%)	*1	
F402	Motor constant #1 (primary resistance)	0.0-30.0 (%)	*1	
F415	Motor rated current	0.1-100.0 (A)	*1	
F416	Motor no-load current	10-90 (%)	*1	
F417	Motor rated rotational speed	100-32000 (min ⁻¹)	*1	
F418	Speed control response coefficient	1-150	40	
F419	Speed control stability coefficient	1-100	20	

● Input/Output Parameters 2

Title	Function	Adjustment range	Default setting	Note
F470	VRF input bias	0-255	128	
F471	VRF input gain	0-255	128	
F472	VRF2 input bias	0-255	128	
F473	VRF2 input gain	0-255	128	

● Torque Boost Parameters 2

Title	Function	Adjustment range	Default setting	Note
F480	Exciting strengthening coefficient	100-130 (%)	100	
F485	Stall cooperation gain at field weakening zone 1	10-250	100	
F492	Stall cooperation gain at field weakening zone 2	50-150	100	
F494	Motor adjustment factor	0-200	*1	

● Acceleration/Deceleration Time Parameters

Title	Function	Adjustment range	Default setting	Note
F500	Acceleration time 2	0.0-3200 (s)	10.0	
F501	Deceleration time 2	0.0-3200 (s)	10.0	
F502	Acceleration/ deceleration 1 pattern	0: Linear, 1: S-pattern 1, 2: S-pattern 2	0	

Table of Parameters

Title	Function	Adjustment range	Default setting	Note
F503	Acceleration/ deceleration 2 pattern	0: Linear, 1: S-pattern 1, 2: S-pattern 2	0	
F504	Selecting an acceleration/ deceleration pattern	1: Acceleration/deceleration 1 pattern 2: Acceleration/deceleration 2 pattern 3: Acceleration/deceleration 3 pattern	1	
F505	Acceleration/deceleration 1 and 2 switching frequency	0.0-UL (Hz)	0.0	
F506	S-pattern lower-limit adjustment amount	0-50%	10	
F507	S-pattern upper-limit adjustment amount	0-50%	10	
F510	Acceleration time 3	0.0-3200 (s)	10.0	
F511	Deceleration time 3	0.0-3200 (s)	10.0	
F512	Acceleration/ deceleration 3 pattern	1: Linear, 2: S-pattern 1, 3: S-pattern 2	0	
F513	Acceleration/deceleration 2 and 3 switching frequency	0.0-UL (Hz)	0.0	

● Protection Parameters

Title	Function	Adjustment range	Default setting	Note
F601	Stall prevention level 1	10-199 (%/A) 200 (Deactivated)	150	
F602	Inverter trip retention selection	0: Cleared if power is turned off 1: Retained even if power is turned off	0	
F603	Emergency stop selection	0: Coast stop 1: Slowdown stop 2: Emergency DC braking	0	
F604	Emergency DC braking time	0.0-20.0 (s)	1.0	
F605	Output phase failure detection mode selection	0: Disabled 1: At start-up (Only one time after power is turned on) 2: At start-up (each time) 3: During operation 4: At start-up + during operation 5: Detection of cutoff on output side	0	
F607	Motor 150%-overload time limit	1-2400 (s)	60	
F608	Input phase failure detection mode selection	0: Disabled, 1: Enabled	1	
F610	Small current trip/alarm selection	0: Alarm only 1: Tripping	0	
F611	Small current detection current	0-100 (%)	0	
F612	Small current detection time	0-255 [sec]	0	
F613	Detection of output short-circuit during start-up	0: Each time (standard pulse) 1: Only one time after power is turned on (standard pulse) 2: Each time (short-time pulse) 3: Only one time after power is turned on (short-time pulse)	0	
F615	Over-torque trip/alarm selection	0: Alarm only 1: Tripping	0	
F616	Over-torque detection level	0-250 (%)	150	
F618	Over-torque detection time	0.0-10.0 [sec]	0.5	
F619	Over-torque detection level hysteresis	0-100 (%)	10	
F621	Cumulative operation time alarm setting	0.0-9.999 (100 hrs)	610	
F625	Overvoltage limit operation level	100-150%	*1	
F627	Undervoltage trip/alarm selection *3	0: Alarm only (detection level below 60%) 1: Tripping (detection level below 60%) 2: Alarm only (detection level below 50%, DC reactor needed)	1	
F633	Trip at VRF low level input mode	0: Disabled 1-100%	0	

*1: Default setting of the parameter differs by each inverter capacity. Refer to "Default settings by Inverter Rating" table on page 19 for actual values.

*2: Unit displayed may be selected by parameter F701 (Unit selection).

*3: Always implement DC reactor (optional) when setting parameter F627 (Undervoltage trip/alarm selection) to "2 (detection level below 50%)."

Title	Function	Adjustment range	Default setting	Note
F634	Annual average ambient temperature (calculation for life alarms)	1: -10 ~ +10°C 2: 11~20°C 3: 21~30°C 4: 31~40°C 5: 41~50°C 6: 51~60°C	3	
F659	Logic output/pulse train output selection (DRV-OM)	0: Logic output 1: Pulse train output	0	
F676	Pulse train output function selection (DRV-OM)	0: Output frequency 1: Output current 2: Set frequency 3: DC voltage 4: Output voltage command value 5: Input power 6: Output power 7: Torque 8: Torque current 9: Motor cumulative load factor 10: Inverter cumulative load factor 11: Braking reactor cumulative load factor 12: Frequency setting value (after PID) 13: VRF Input value 14: VRF2 Input value 15: Fixed output 1 (Output current: 100%) 16: Fixed output 2 (Output current: 50%) 17: Fixed output 3 (Other than the output current: 100%)	0	
F677	Maximum numbers of pulse train	500-1600 (PPS)	800	
F691	Inclination characteristic of	0: Negative inclination (downward slope) 1: Positive inclination (upward slope)	1	
F692	analog output Bias of analog output	0-100%	0	

● Operation Panel Parameters

Title	Function	Adjustment range	Default setting	Note
F700	Prohibition of change of parameter setting	0: Permitted, 1: Prohibited	0	
F701	Current/voltage display mode	0: % 1: A (ampere)/V (volt)	1	
F702	Frequency free unit magnification	0.00: Free unit display disabled (display of frequency) 0.01-200.0 (times)	0.00	
F705	Inclination characteristic of free unit display	0: Negative inclination (downward slope) 1: Positive inclination (upward slope)	1	
F706	Bias of free unit display	0.00-FH (Hz)	0.00	
F707	Free step 1 (pressing a panel key once)	0.00: Disabled 0.01-FH (Hz)	0.00	
F708	Free step 2 (panel display)	0: Disabled 1-255	0	
F710	Standard monitor display selection	0: Operation frequency (Hz/free unit) 1: Frequency command (Hz/free unit) 2: Output current (%/A) 3: Inverter rated current (A) 4: Inverter load factor (%) 5: Output power (kW) 6: Frequency command after PID control (Hz/free unit) 7: Optional item specified from an external control unit	0	
F719	Canceling of operation command when standby terminal (ST) is turned off	0: Operation command canceled (cleared) 1: Operation command retained	1	
F721	Selection of operation panel stop pattern	0: Slowdown stop 1: Coast stop	0	

Table of Parameters

Title	Function	Adjustment range	Default setting	Note
F730	Panel operation prohibition (FC)	0: Permitted, 1: Prohibited	0	
F733	Prohibition of panel operation (RUN/STOP keys)	0: Permitted, 1: Prohibited	0	
F734	Prohibition of panel emergency stop operation	0: Permitted, 1: Prohibited	0	
F735	Prohibition of panel reset operation	0: Permitted, 1: Prohibited	0	
F736	Prohibition of change of CMod/FMod during operation	0: Permitted, 1: Prohibited	1	

● Communication Parameters

Title	Function	Adjustment range	Default setting	Note
F800	Communication band speed	0: 1200bps 1: 2400bps 2: 4800bps 3: 9600bps 4: 19200bps	3	
F801	Parity (Common serial)	0: NON (No parity) 1: EVEN (Even parity) 2: ODD (Odd parity)	1	
F802	Inverter number	0-255	0	
F803	Communication error trip time	0: Disabled (*) 1-100 (s)	0	
F805	Communication waiting time	0.00-2.00 (s)	0.00	
F806	Setting of master and slave inverters for communications between inverters	0: Slave inverter (0 Hz command issued in case the master inverter fails) 1: Slave inverter (Operation continued in case the master inverter fails) 2: Slave inverter (Emergency stop tripping in case the master inverter fails) 3: Master inverter (transmission of frequency commands) 4: Master inverter (transmission of output frequency signals)	0	
F811	Point # 1 setting	0-100 (%)	0	
F812	Point # 1 frequency	0-500.0 (Hz)	0.0	
F813	Point # 2 setting	0-100 (%)	100	
F814	Point # 2 frequency	0-500.0 (Hz)	60.0	

● Default Settings by Inverter Rating

Inverter type	Torque boost	Dynamic braking resistance	Dynamic braking resistor capacity	Slip frequency gain	Motor constant #1 (primary resistance)	Motor rated current	Motor no-load current	Motor rated speed	Motor adjustment factor	Over-voltage stall protection level
	Ub/F 172 (%)	F308 (Ω)	F309 (kW)	F401 (%)	F402 (%)	F415 (A)	F416 (%)	F417 (r/min)	F494	F526 (%)
HF321S-A20	6.0	400.0	0.2	100	7.0	1.5	85	1750	90	134
HF321S-A40	6.0	200.0	0.2	80	6.4	2.3	84	1735	90	134
HF321S-A75	6.0	200.0	0.3	70	4.7	3.9	75	1740	80	134
HF321S-1A5	6.0	80.0	0.3	80	5.0	6.6	55	1720	70	134
HF321S-2A2	5.0	70.0	0.4	75	3.8	9.3	55	1745	70	134
HF3212-A20	6.0	400.0	0.2	100	7.0	1.5	85	1750	90	134
HF3212-A40	6.0	200.0	0.2	80	6.4	2.3	84	1735	90	134
HF3212-A75	6.0	200.0	0.3	70	4.7	3.9	75	1740	80	134
HF3212-1A5	6.0	80.0	0.3	80	5.0	6.6	55	1720	70	134
HF3212-2A2	5.0	70.0	0.4	75	3.8	9.3	55	1745	70	134
HF3212-3A7	5.0	40.0	0.6	80	3.6	14.8	44	1740	70	134
HF3212-5A5	4.0	20.0	1.5	75	3.8	21.5	42	1750	70	134
HF3212-7A5	3.0	20.0	1.5	75	4.0	29.1	43	1755	70	134
HF3214-A40	6.0	750.0	0.2	76	6.4	1.2	82	1735	90	140
HF3214-A75	6.0	750.0	0.3	70	4.2	1.9	75	1740	80	140
HF3214-1A5	6.0	400.0	0.3	80	5.4	3.3	55	1720	70	140
HF3214-2A2	5.0	250.0	0.4	75	3.5	4.7	55	1745	70	140
HF3214-3A7	5.0	160.0	0.6	85	3.2	7.4	44	1740	70	140
HF3214-5A5	4.0	83.0	1.2	65	3.9	10.7	42	1750	70	140
HF3214-7A5	3.0	83.0	1.2	75	3.6	14.6	43	1755	70	140

Title	Function	Adjustment range	Default setting	Note
F829	Selection of communication protocol	0: Sumitomo Inverter protocol 1: Modbus RTU protocol	0	
F870	Block write data 1	0: No selection 1: Command information 1	0	
F871	Block write data 2	2: Command information 2 3: Frequency command 4: Output data on the terminal board 5: Analog output for communications	0	
F875	Block read data 1	0: No selection 1: Status information	0	
F876	Block read data 2	2: Output frequency 3: Output current	0	
F877	Block read data 3	4: Output voltage	0	
F878	Block read data 4	5: Alarm information 6: PID feedback value	0	
F879	Block read data 5	7: Input terminal board monitor 8: Output terminal board monitor 9: VRF terminal board monitor 10: VRF2 terminal board monitor	0	
F880	Free notes	0-65535	0	
F890	Parameters for option 1	0-65535	0	
F891	Parameters for option 2	0-65535	0	
F892	Parameters for option 3	0-65535	0	
F893	Parameters for option 4	0-65535	0	
F894	Parameters for option 5	0-65535	0	

● Unused Parameter

Title	Function	Adjustment range	Default setting	Note
F910	-	Do not change	100	
F911	-	Do not change	0.0	

- *1: Default setting of the parameter differs by each inverter capacity. Refer to "Default settings by Inverter Rating" table below for actual values.
- *2: Unit displayed may be selected by parameter F701 (Unit selection).
- *3: Always implement DC reactor (optional) when setting parameter F527 (Undervoltage trip/alarm selection) to "2" (detection level below 50%)."

Table of Parameters

Input/Output Terminal Functions

Allocating the function numbers in the table below to the parameters F110–F118 (input terminal selection) and F130–F138 (output terminal selection) will assign various roles to contact input/output terminals.

Table of Input Terminal Functions

Function No.	Function
1	Standby terminal
2	Forward run command
3	Reverse run command
4	Jog run mode
5	Acceleration/deceleration 2 pattern selection
6	Preset-speed command 1
7	Preset-speed command 2
8	Preset-speed command 3
9	Preset-speed command 4
10	Reset command
11	Trip stop command from external input device
12	Switching of command mode and frequency setting mode
13	DC braking command
14	PID control prohibited
15	Permission of parameter editing
16	Combination of standby and reset commands (No.1 + 10)
17	Combination of standby and command/frequency setting mode switching (No.1 + 12)
18	Combination of forward run and jog run (No.2 + 4)
19	Combination of reverse run and jog run (No.3 + 4)
20	Combination of forward run and acceleration/deceleration 2 (No.2 + 5)
21	Combination of reverse run and acceleration/deceleration 2 (No.3 + 5)
22	Combination of forward run and preset-speed command 1 (No.2 + 6)
23	Combination of reverse run and preset-speed command 1 (No.3 + 6)
24	Combination of forward run and preset-speed command 2 (No.2 + 7)
25	Combination of reverse run and preset-speed command 2 (No.3 + 7)
26	Combination of forward run and preset-speed command 3 (No.2 + 8)
27	Combination of reverse run and preset-speed command 3 (No.3 + 8)
28	Combination of forward run and preset-speed command 4 (No.2 + 9)
29	Combination of reverse run and preset-speed command 4 (No.3 + 9)
30	Combination of forward run, preset-speed command 1 and acceleration/deceleration 2 (No.2 + 5 + 6)
31	Combination of reverse run, preset-speed command 1 and acceleration/deceleration 2 (No.3 + 5 + 6)
32	Combination of forward run, preset-speed command 2 and acceleration/deceleration 2 (No.2 + 5 + 7)
33	Combination of reverse run, preset-speed command 2 and acceleration/deceleration 2 (No.3 + 5 + 7)
34	Combination of forward run, preset-speed command 3 and acceleration/deceleration 2 (No.2 + 5 + 8)
35	Combination of reverse run, preset-speed command 3 and acceleration/deceleration 2 (No.3 + 5 + 8)
36	Combination of forward run, preset-speed command 4 and acceleration/deceleration 2 (No.2 + 5 + 9)
37	Combination of reverse run, preset-speed command 4 and acceleration/deceleration 2 (No.3 + 5 + 9)
38	Frequency command forced switching to F207
39	No.2 Switching of V/F setting
40	No.2 motor switching (No.5 + 39 + 61)
41	Frequency UP signal input from external contacts
42	Frequency DOWN signal input from external contacts
43	Frequency UP/DOWN cancellation signal input from external contacts
44	Combination of frequency UP/DOWN cancellation and reset by means of external contacts (No.10 + 43)
45	Inversion of trip stop command from external device (Inversion of No.11)
46	Thermal trip stop signal input from external device
47	Inversion of thermal trip stop command from external device (Inversion of No.46)
48	Forced switching from remote to local control
49	Operation holding (stop of 3-wire operation)
50	Forced switching of command mode and terminal board command
51	Display cancellation of the cumulative power amount (kWh)
52	Forced operation (factory configuration required)
53	Fire-speed control
54	Inversion of standby terminal (Inversion of No.1)
55	Inversion of reset command (Inversion of No.10)

Function No.	Function
56	Combination of forward run and standby (No.1 + 2)
57	Combination of reverse run and standby (No.1 + 3)
58	Acceleration/deceleration 3 selection
59	Combination of forward run and acceleration/deceleration 3 (No.2 + 58)
60	Combination of reverse run and acceleration/deceleration 3 (No.3 + 58)
61	Forced switching of stall prevention level 2
62	Holding of RY-RC terminal output
63	Holding of OUT-OM terminal output
64	Cancellation (clearing) of operation command from panel

Table of Output Terminal Functions

Function No.	Function
0/1	Frequency lower limit/its inversion
2/3	Frequency upper limit/its inversion
4/5	Low-speed detection signal/its inversion
6/7	Designated frequency attainment signal (completion of acceleration/deceleration) /its inversion
8/9	Set frequency attainment signal/its inversion
10/11	Failure signal (trip output)/its inversion
12/13	Over-torque detection/its inversion
14/15	RUN&STOP/its inversion
16/17	OL pre-alarm/its inversion
18/19	Braking resistor overload pre-alarm/its inversion
20/21	Over-torque detection pre-alarm/its inversion
22/23	Pre-alarm/its inversion
24/25	Small-current detection/its inversion
26/27	Significant failure/its inversion
28/29	Insignificant failure/its inversion
30/31	Ready for operation (including ST/RUN)/its inversion
32/33	Ready for operation (excluding ST/RUN)/its inversion
34/35	Frequency VRF2 selection/its inversion
36/37	Fault signal (put out also at the time of a retry)/its inversion
38/39	Specified data output 1/its inversion
40/41	Specified data output 2/its inversion
42/43	Cumulative operation time alarm/its inversion
44/45	Calculation for life alarm/its inversion
46/47	Braking sequence output/its inversion
48/49	FR terminal input signal/its inversion
50/51	RR terminal input signal/its inversion
52/53	Signal in accordance of frequency command/its inversion
54/55	Undervoltage detection/its inversion
56–253	Invalid settings, always OFF (ignored)
254	Always OFF
255	Always ON

Note 1: Even-numbered functions are positive logic and odd-numbered functions are negative logic for Functions 0–55.

Explanation of Function

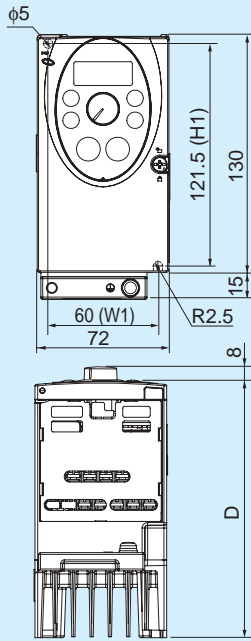

Fig. A

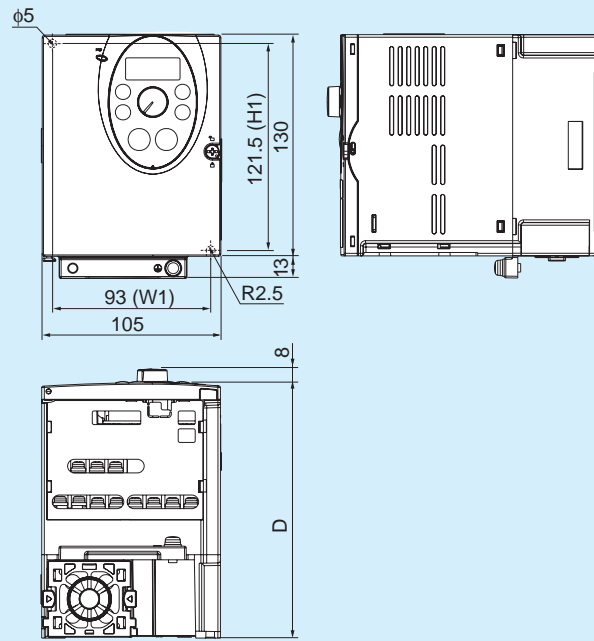

Fig. B

Note 1: To make it easier to grasp the dimensions of each inverter, dimensions common to all inverters in these figures are shown with numeric values but not with symbols. Here are the meanings of the symbols used.

- W: Width
- H: Height
- D: Depth
- W1: Mounting dimension (horizontal)
- H1: Mounting dimension (vertical)
- H2: Height of EMC plate mounting area
- D2: Height of frequency setting knob

Input voltage	Applicable motor (kW)	Inverter type	Dimensions (mm)							Drawing	Approx. weight (kg)
			W	H	D	W1	H1	H2	D2		
3-phase 200V	0.2	HF3212-A20	72	130	120	60	121.5	15	8	A	0.9
	0.4	HF3212-A40			130						0.9
	0.75	HF3212-A75			130						1.1
	1.5	HF3212-1A5	105	130	130	93	121.5	13		B	1.2
	2.2	HF3212-2A2			150						1.3
	3.7	HF3212-3A7	140	170	150	126	157	14		C	2.2
	5.5	HF3212-5A5	180	220	170	160	210	12		D	4.8
	7.5	HF3212-7A5									4.9

Applicable Wiring for Accessories and Options

Standard Accessories

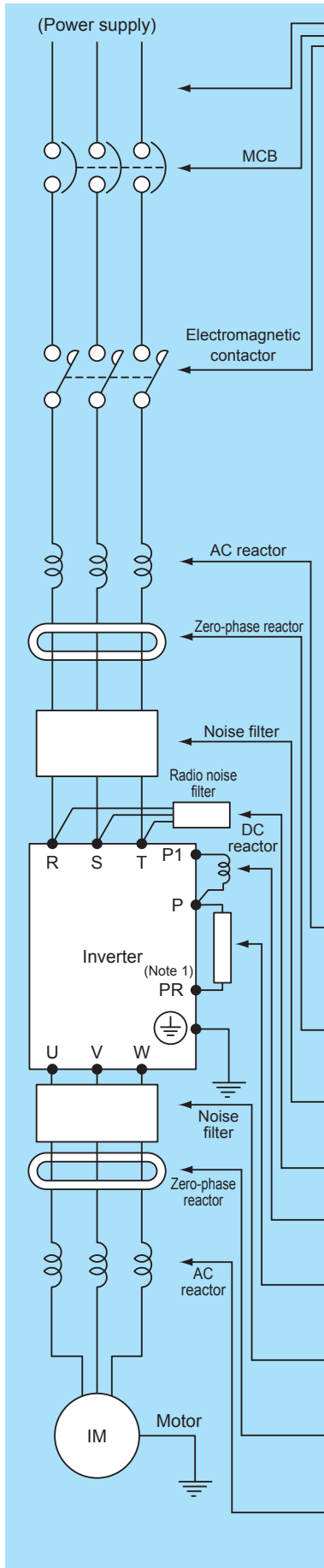

Rated input voltage	Applicable motor (kw)	Inverter model	Circuit breaker (made by Mitsubishi Electric)		Electromagnetic contactor (made by Fuji Electric)	Cable size 30m (mm ²)
			Rated current (A)	Type	Type	
1-phase 200V class	0.2	HF321S-A20	10	NF-30	SC-03	2
	0.4	HF321S-A40	15	NF-30	SC-03	2
	0.75	HF321S-A75	20	NF-30	SC-03	2
	1.5	HF321S-1A5	30	NF-30	SC-1N	2
	2.2	HF321S-2A2	40	NF-50	SC-2N	2
3-phase 200V class	0.2	HF3212-A20	5	NF-30	SC-03	2
	0.4	HF3212-A40	5	NF-30	SC-03	2
	0.75	HF3212-A75	10	NF-30	SC-03	2
	1.5	HF3212-1A5	15	NF-30	SC-1N	2
	2.2	HF3212-2A2	20	NF-30	SC-1N	2
	3.7	HF3212-3A7	30	NF-30	SC-2N	3.5
	5.5	HF3212-5A5	50	NF-50	SC-2N	5.5
3-phase 400V class	0.4	HF3214-A40	5	NF-30	SC-03	2
	0.75	HF3214-A75	5	NF-30	SC-03	2
	1.5	HF3214-1A5	10	NF-30	SC-03	2
	2.2	HF3214-2A2	15	NF-30	SC-1N	2
	3.7	HF3214-3A7	20	NF-30	SC-1N	2
	5.5	HF3214-5A5	30	NF-30	SC-1N	2
	7.5	HF3214-7A5	30	NF-30	SC-1N	3.5

Note: 1. The shown accessories are for use with SUMITOMO 3-phase, 4-pole motors.

2. Select the circuit breaker based on required capacity.

3. Use thicker cables when wiring distance exceeds 30 m.

*The alarm output point should be 0.75 mm².

When using an earth leakage breaker (ELB), select the breaker's trip current from the table below based on the total wire distance (R) by summing the distance from the breaker to the inverter and the inverter to the motor.

ℓ	Trip current (mA)
100m or less	30
300m or less	100
600m or less	200

Note: 1. When CV wiring is used in metal conduit, the leakage current is approximately 30mA/km.
2. Leakage current will increase eightfold with IV type cable due to higher dielectric constant. In this case, use ELB with the next higher trip rating.

Input AC reactor for harmonic suppression/power smoothing/powerfactor improvement	This is useful in suppressing harmonics induced on the power supply lines, or when the main power voltage imbalance exceeds 3%, (and power source capacity is more than 500kVA), or to smooth out line fluctuations. It also improves the power factor.
Radio noise filter Zero-phase reactor	Electrical noise interference may occur on nearby equipment such as a radio receiver. This magnetic choke filter helps reduce radiated noise.
Input noise filter	This filter reduces the conducted noise in the power supply wiring between the inverter and the power distribution system. Connect it to the inverter primary (input side).
Input radio noise filter (XY filter)	This capacitive filter reduces radiated noise from the main power wires in the inverter input side.
DC reactor	The inductor or choke filter suppresses harmonics generated by the inverter.
Regenerative braking resistor HF-320 only	The regenerative braking resistor is useful for increasing the inverter's control torque for high duty-cycle (on-off) applications, and improving the decelerating capacity.
Output noise filter	This filter reduces radiated noise emitted on the inverter output cable that may interfere with radio or television reception and test equipment and sensor operation.
Radio noise filter Zero-phase reactor	Electrical noise interference may occur on nearby equipment such as a radio receiver. This magnetic choke filter helps reduce radiated noise.
Output AC reactor	Install it on the output side to reduce leakage current contributed by higher harmonics. Contact our company for details.

Peripheral Equipment

■ Caution in Selecting Peripheral Equipment

Wiring and connection		<ol style="list-style-type: none"> 1. Be sure to connect the power supply to RST (input terminals) and the motor to U, V, W (output terminals). 2. Be sure to connect the grounding terminal. (Ⓧ mark) Inverters generate high frequency, increasing leakage current. Be sure to ground the inverter and motor.
Wiring between inverter and motor	Electromagnetic contactor	When using an electromagnetic contactor between the inverter and motor, do not turn the contactor ON or OFF during inverter operation.
	Thermal relay	<p>Install a thermal relay that matches the motor in the following cases:</p> <ul style="list-style-type: none"> *Install a thermal relay for each motor when operating more than one motor with one inverter. *Set the current of the thermal relay at the rated motor current x 1.1. When the wiring length is long (more than 10 m), the thermal relay may be activated too quickly. Install an AC reactor or current sensor on the output side. *When motors are to be operated with the rated current exceeding the adjustable level of the built-in electronic thermal relay.
Earth leakage breaker		Install an earth leakage breaker on the input side for protection of the inverter wiring and operators. Conventional earth leakage breakers may malfunction because of high harmonics from the inverter; therefore use an earth leakage breaker that is applicable to the inverter. The leakage current differs according to the cable length. Refer to p.23.
Wiring distance		<p>The wiring distance between the inverter and operation panel should be less than 30m. If it exceeds 30m, use a current/voltage converter, etc. Use shielded cable for wiring.</p> <p>When the wiring distance between the motor and inverter is long, the leakage current from high harmonics may cause the protective function of the inverter and peripheral equipment to be activated. The situation will be improved by an AC reactor installed on the output side of the inverter. Select appropriate cable to prevent voltage drop. (Large voltage drop lowers the torque.)</p>
Phase-advanced capacitor		<p>Do not use a phase-advanced capacitor.</p> <p>When a power factor improving capacitor is connected between the inverter and motor, the capacitor may be heated or broken by the higher harmonics in the inverter output.</p>

■ Frequency Setting Unit: VR-07 1kW, 2W

Unit VR07

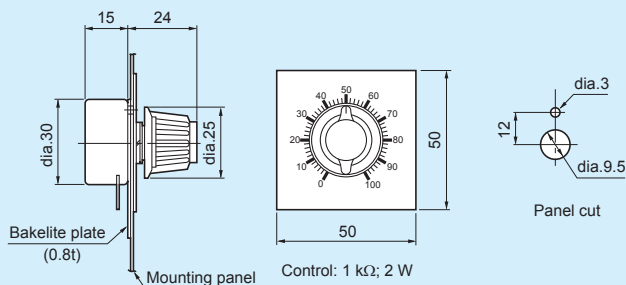

■ Remote Operator

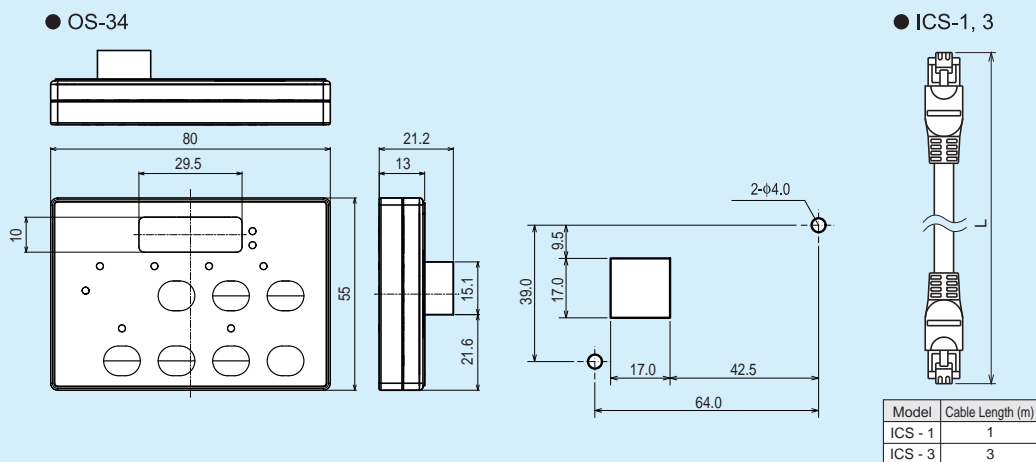

■ Braking Resistor Options for HF-320α

Rated power (W)	Dimensions								Weight (g)
	F	G	H	J	K	L	M	N	
200	28	26	22	6	53	287	306	4	340
300	44	40	40	10	78	309	335	5	840
400	44	40	40	10	78	385	411	5	1000
750	57	40	40	10	84	355	381	5	1360

100% braking torque: 10 sec 10% ED

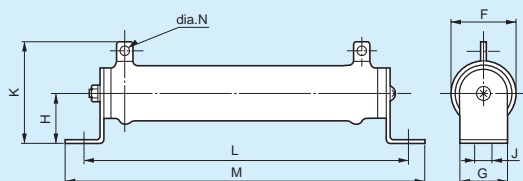

Voltage (V)	Capacity (kW)	Braking resistor				Thermal relay set value (A)
		Part No.	Rated power	Resistance	Qty	
200V	0.2	Y135AA201	200W	400 Ω	1	0.83
	0.4	Y135AA200	200W	200 Ω	1	0.83
	0.75	Y135AA205	300W	200 Ω	1	1.25
	1.5	Y135AA204	300W	80 Ω	1	1.25
	2.2	Y135AA208	400W	70 Ω	1	1.7
	3.7	Y135AA203	300W	20 Ω	2-pc series	2.1
	5.5	X435AC069	750W	10 Ω	2-pc series	5.3
	7.5	X435AC069	750W	10 Ω	2-pc series	5.3
400V	0.4	Y135AA202	200W	750 Ω	1	0.42
	0.75	Y135AA207	300W	750 Ω	1	0.63
	1.5	Y135AA206	300W	400 Ω	1	0.63
	2.2	Y135AA209	400W	250 Ω	1	0.83
	3.7	Y135AA204	300W	80 Ω	2-pc series	1.1
	5.5	Y135AA209	400W	250 Ω	3-pc series	2.0
	7.5	Y135AA209	400W	250 Ω	3-pc series	2.0

Type of thermal relay: TR-ONH

Peripheral

■ % Speed Meter: DCF-12N

0-100%; 50divisions

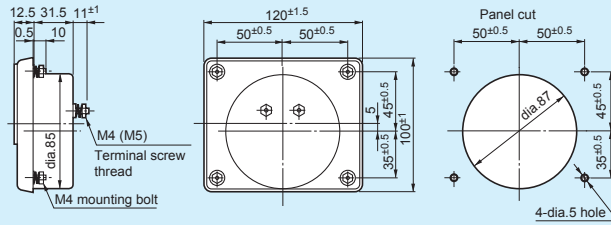

Part No.	
X525AA014	1mA F.S.
X525AA048	10V F.S.

■ AC Ammeter: ACF-12N

The CT directly detects the current of the secondary side of the inverter.

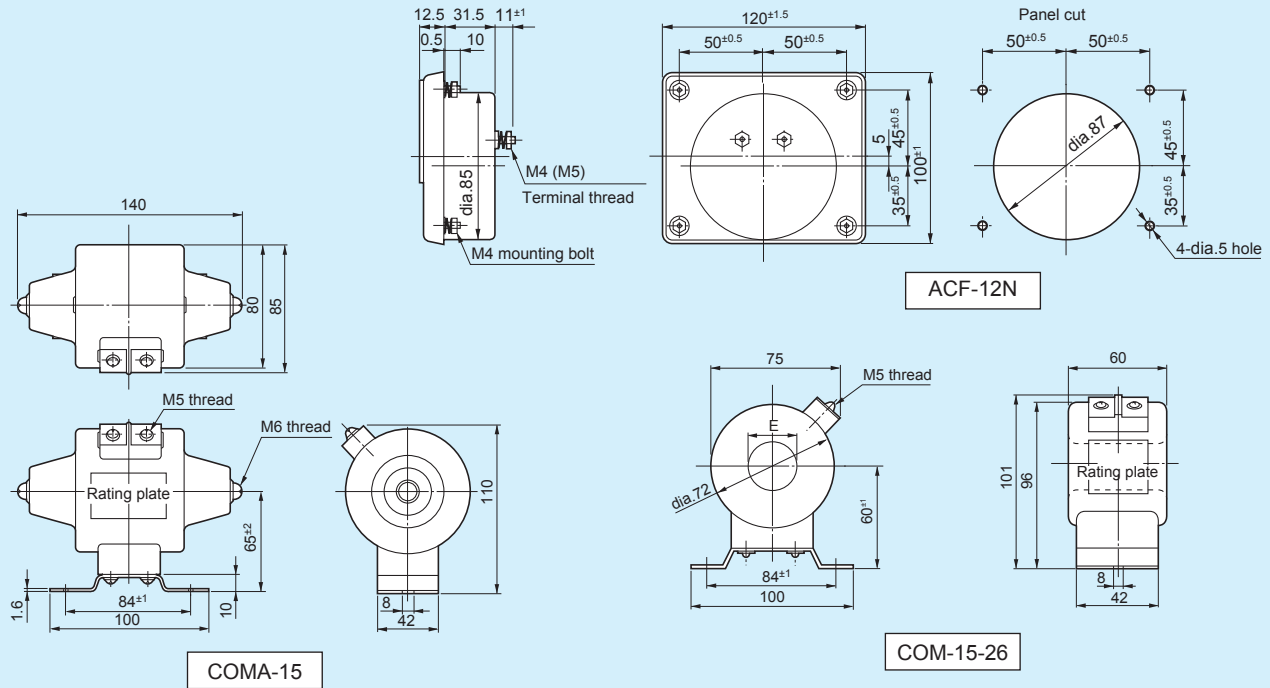

Table of combination of AC ammeter (ACF-12N) and current transformer

Motor capacity (kW)	200V class					400V class				
	Part No.	Meter		CT Type	Number of primary through holes	Part No.	Meter		CT Type	Number of primary through holes
Rated current [A]	Max. scale [A]	Part No.	Rated current [A]			Max. scale [A]				
0.2	X525AA078	3	3	COMA-15 5/5A	-	-	-	-	-	-
0.4	X525AA079	5	5	COMA-15 5/5A	-	X525AA078	3	3	COMA-15 5/5A	-
0.75	X525AA080	5	10	COMA-15 10/5A	-	X525AA079	5	5	COMA-15 5/5A	-
1.5	X525AA081	5	15	COMA-15 15/5A	-	X525AA080	5	10	COMA-15 10/5A	-
2.2	X525AA082	5	20	COMA-15 20/5A	-	X525AA080	5	10	COMA-15 10/5A	-
3.7	X525AA083	5	30	COMA-15 30/5A	-	X525AA081	5	15	COMA-15 15/5A	-
5.5	X525AA042	5	50	COM-15-26 50/5A	3	X525AA082	5	20	COMA-15 20/5A	-
7.5	X525AA042	5	50	COM-15-26 50/5A	3	X525AA083	5	30	COMA-15 30/5A	-

Construction of current transformer (CT) COMA-15 type: Totally molded current transformer with primary winding

COM-15-26 type: Totally molded current transformer, throughhole type

Install the current transformer (CT) on the output side of the inverter.

■ DC Reactor for Power Factor Improvement and Higher Harmonics Control

A DC reactor is available for improvement of the power factor of the inverter, ensuring power line impedance, and control of higher harmonics.

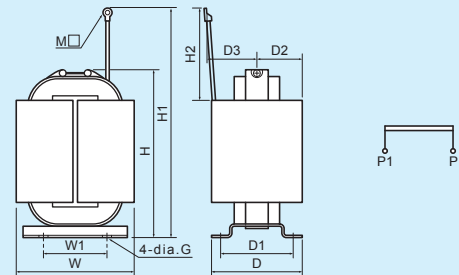

Note: Attaching the DC or AC reactor indicated in this catalog for 200V class under 3.7kW inverter conforms to Suppression Measures for Higher Harmonics for General Inverter (with input source lower than 20A) determined by Japan Electrical Manufacturers' Association (JEMA).

	Applicable capacity (kW)	Specification		Part No. Y220DA	W	W1	D	D1	D2	D3	H	H1	H2	G	Connection Terminal	Weight (kg)	Insulation
		Current (A)	L (mH)														
200V Series	0.2	1.0	29.7	032	52	35	40	32	20	22	65	-	300	dia.4	M4	0.3	B
	0.4	2.0	14.8	033	52	35	40	32	20	22	75	-	300	dia.4	M4	0.4	B
	0.75	3.75	9.72	034	52	35	50	42	25	27	85	-	300	dia.4	M4	0.6	B
	1.5	7.5	4.83	035	74	50	45	37	-	-	120	145	-	dia.5	M5	1.0	B
	2.2	11.0	3.41	036	74	50	45	37	-	-	120	145	-	dia.5	M5	1.1	B
	3.7	18.5	2.13	037	90	60	62	52	-	-	140	170	-	dia.5	M8	2.0	B
	5.5	28.0	1.47	038	90	60	62	52	-	-	140	170	-	dia.5	M5	2.4	B
7.5	38.0	1.11	039	100	80	95	80	-	-	140	170	-	5.557	M5	3.5	B	
400V Series	0.4	1.0	59.3	003	52	35	40	32	20	22	75	-	300	dia.4	M4	0.4	B
	0.75	1.88	38.9	004	52	35	50	42	25	27	85	-	300	dia.4	M4	0.6	B
	1.5	3.75	19.3	005	59	40	60	47	30	35	100	-	300	dia.4	M4	0.9	B
	2.2	5.5	13.7	006	74	50	45	37	-	-	120	140	-	dia.5	M5	1.1	B
	3.7	9.25	8.52	007	74	50	70	62	-	-	120	145	-	dia.5	M5	1.8	B
	5.5	14.0	5.87	008	90	60	62	52	-	-	140	165	-	dia.5	M5	1.5	B
	7.5	19.0	4.46	009	100	80	95	80	-	-	140	165	-	5.557	M5	3.5	B

■ AC Reactor for Power Factor Improvement and Higher Harmonics Control

An AC reactor is available for improvement of the power factor of the inverter, ensuring proper power line impedance, and control of higher harmonics.

* The AC reactor is for 3-phase input.

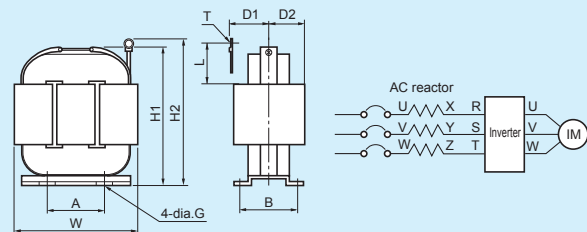

Note: Attaching the DC or AC reactor indicated in this catalog for 200V class under 3.7kW inverter conforms to Suppression Measures for Higher Harmonics for General Inverter (with input source lower than 20A) determined by Japan Electrical Manufacturers' Association (JEMA).

	Applicable capacity (kW)		Specification		Part No. Y220DA	W	D1	D2	H1	H2	A	B	G	L	T	Weight (kg)	Insulation
	Current(A)	Current(A)	Current (A)	L (mH)													
200V Series	0.4	0.2	2.1	5.8	053	90	35	30	100	-	50	38	4	300	M4	1.0	B
	0.75	0.4	4.0	3.1	054	90	35	30	100	-	50	38	4	300	M4	1.1	B
	1.5	0.75	8.0	1.6	055	90	40	35	100	120	55	48	4	-	M4	1.6	B
	2.2	-	11	1.2	056	115	42	37	120	145	55	43	4	-	M4	2.1	B
	3.7	1.5/2.2	17	0.7	057	115	42	37	120	145	55	43	4	-	M5	2.4	B
	5.5	-	24	0.5	058	155	45	40	150	180	80	50	5	-	M5	3.9	F
400V Series	0.4	-	1.2	22	080	90	35	30	100	-	50	38	4	300	M4	1.0	B
	0.75	-	2.1	12	081	90	35	30	100	-	50	38	4	300	M4	1.1	B
	1.5	-	4.0	6.5	082	90	40	35	100	-	55	48	4	300	M4	1.7	B
	2.2	-	5.5	4.6	083	115	42	37	120	-	55	43	4	300	M4	2.5	B
	3.7	-	9.0	2.9	084	115	42	37	120	145	55	43	4	-	M4	2.8	B
	5.5	-	13	2.0	085	155	45	40	150	175	80	50	5	-	M4	4.2	B
	7.5	-	17	1.5	086	155	45	40	150	175	80	50	5	-	M5	4.4	B

Peripheral

■ Noise Filter

3-phase 200V class

Applicable motor (kW)	Input side		Output side	
	Type	Part No.	Type	Part No.
0.2 ~ 0.4	NF3010A-VZ	X480AC289	CC3005C-P	X480AC163
0.75 ~ 1.5			CC3010C-P	X480AC164
2.2	NF3020A-VZ	X480AC290	CC3015C-P	X480AC165
3.7			CC3020C-P	X480AC166
5.5	NF3030A-VZ	X480AC291	CC3030C-P	X480AC167
7.5	NF3040A-VZ	X480AC292	CC3045C-P	X480AC168

1-phase 200V class

Applicable motor (kW)	Input side		Output side	
	Type	Part No.	Type	Part No.
0.2 ~ 0.4	NF3010A-VZ	X480AC289	CC3005C-P	X480AC163
0.75			CC3010C-P	X480AC164
1.5	NF3020A-VZ	X480AC290	CC3015C-P	X480AC165
2.2	NF3030A-VZ	X480AC291	CC3020C-P	X480AC166

3-phase 400V class

Applicable motor (kW)	Input side		Output side	
	Type	Part No.	Type	Part No.
0.4 ~ 1.5	NF3010C-VZ	X480AC296	CC3005C-P	X480AC163
2.2 ~ 3.7			CC3010C-P	X480AC164
5.5	NF3020C-VZ	X480AC297	CC3015C-P	X480AC165
7.5			CC3020C-P	X480AC166

Input-side Noise Filter

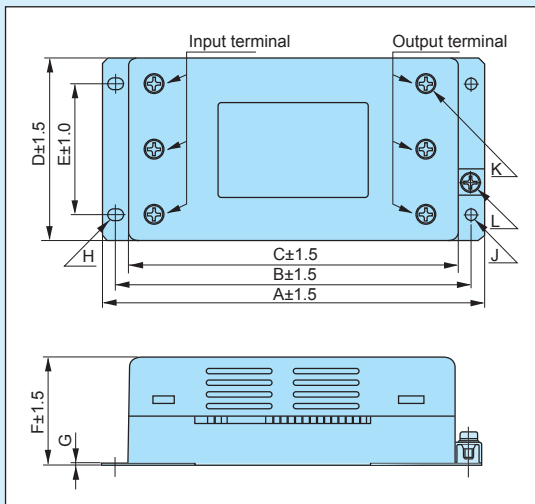

Output-side Noise Filter

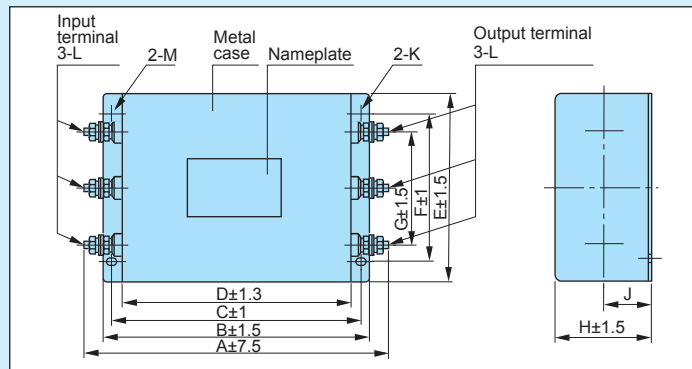

Output side	Dimensions (Unit: mm)												
	Type	A	B	C	D	E	F	G	H	J	K	L	M
CC3005C-P													
CC3010C-P	147	140	125	110	95	70	50	50	25	φ 4.5	M4	R2.25 length 6	
CC3015C-P													
CC3020C-P	167	160	145	130	110	80	60	70	35	φ 5.5	M5	R2.75 length 7	
CC3030C-P	215	200	185	170	120	90	70	70	35	φ 5.5	M5	R2.75 length 7	
CC3045C-P	255	230	215	200	140	110	80	80	40	φ 6.5	M6	R3.25 length 8	

Input side	Dimensions (Unit: mm)										
	Type	A	B	C	D	E	F	G	H	J	K
X480AC289	128	118	108	63	43	42	1.0	4.5 x 6	φ4.5	M4	M4
X480AC290											
X480AC291	145	135	125	70	50						
X480AC292	179	167	155	90	70	54	1.6				M5
X480AC296	128	118	108	63	43	42	1.0				M4
X480AC297											

1. Connect the input-side filter between the power supply and inverter input terminal, and the output-side filter between the inverter output terminal and motor. Make the connection cable as short as possible.
2. Use grounding cable as thick as possible. Correctly ground the equipment.
3. The input and output cables of the filter should be sufficiently separated.
4. Do not connect the input-side filter to the inverter output (motor) side.

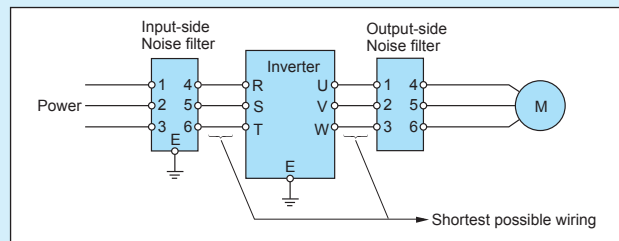

■ Zero-phase Reactor (inductive filter)

Common to 200 V and 400 V classes, as well as input and output sides

· 3.7 kW or less
 Part No. X480AC188
 Type RC5078

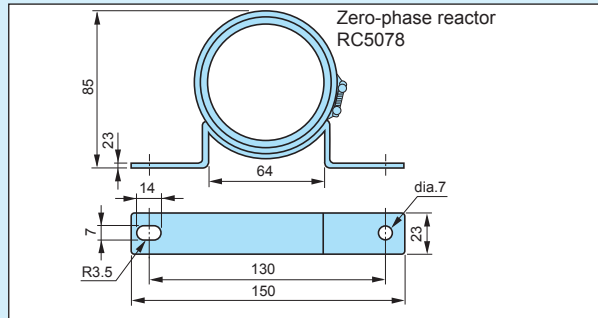

Winding turns	More than 3 times (4T)
Qty used	1 pc
Winding	

· 5.5 kW or more
 Part No. X480AC192
 Type RC9129

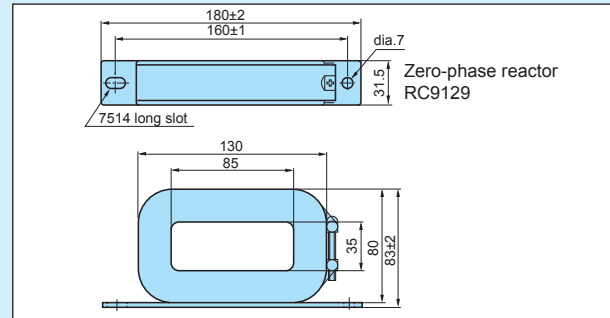

Method of connection

1. It can be used on both input (power supply) side and output (motor) side of the inverter.
2. Wind the cables of the three phases respectively on the input or output side more than three times (4 turns) in the same direction. If cables are too thick to wind more than three times (4 turns), arrange two or more zero-phase reactors to reduce the number of winding turns.
3. Make the gap between the cable and the inside of the core as small as possible.

■ When AM Radio Picks Up Noise

1. When noise level is high

Take possible measures among the following in the order of 1 to 7.

7. Each measure will improve noise reduction.

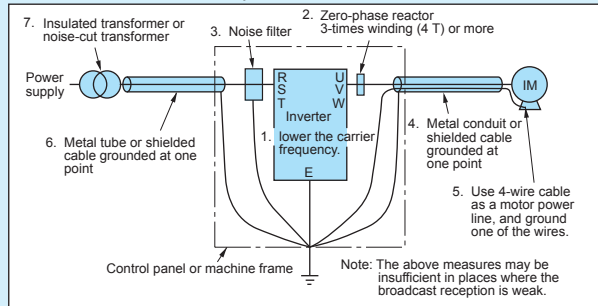

■ Corrective measures

1. Lower the carrier frequency as much as possible. Up to approx. 10 kHz when low-noise operation is necessary.
2. Install a zero-phase reactor on the output side of the inverter. (Type: RC9129)
3. Install an Noise filter on the input side of the inverter. (□□□□-FS)
4. Connect the inverter and motor with a metal conduit or shielded cable.
5. Use 4-wire cable as a motor power line, and ground one of the wires.
6. Connect the inverter and power with a metal conduit or shielded cable.
7. Install a drive isolation or noise reduction transformer for the power supply.
 □□□□ differs according to the inverter capacity and voltage.

■ Connection of 2 zero-phase reactor and 3 Noise filter

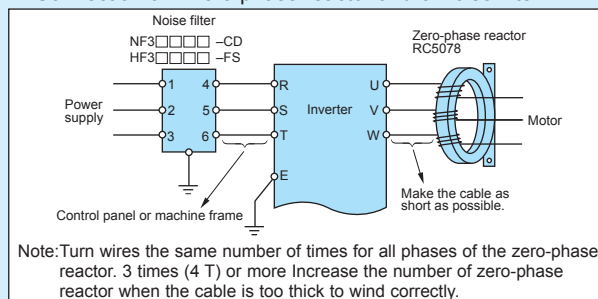

Note: Turn wires the same number of times for all phases of the zero-phase reactor. 3 times (4 T) or more. Increase the number of zero-phase reactor when the cable is too thick to wind correctly.

2. When noise level is low

Take possible measures among the following in the order of 1 to 6.

Each measure will improve noise reduction.

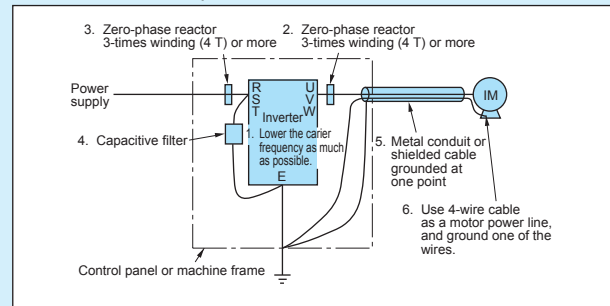

■ Corrective measures

1. Lower the carrier frequency as much as possible. Up to approx. 10 kHz when low-noise operation is necessary.
2. Install a zero-phase reactor on the output side of the inverter. (Type: RC5078, RC9129)
3. Install a zero-phase reactor on the input side the inverter. (Type: RC5078, RC9129)
4. Install a capacitive filter on the input side of the inverter. (Type: 3XYHB-105104)
5. Connect the inverter and motor with a metal conduit or shielded cable.
6. Use 4-wire cable as a motor power line, and ground one of the wires.

■ Connection of 2, 3 zero-phase reactor and 4 capacitive filter

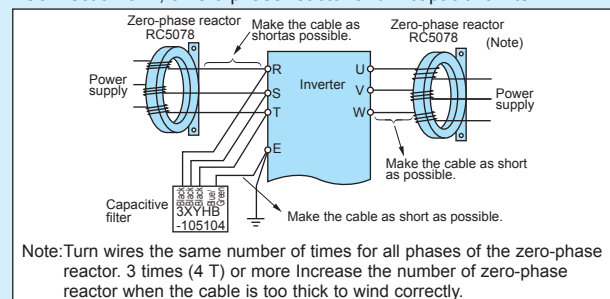

Note: Turn wires the same number of times for all phases of the zero-phase reactor. 3 times (4 T) or more. Increase the number of zero-phase reactor when the cable is too thick to wind correctly.

Notes to Inverter Users

Measures to Take When Proximity Switch/photoelectric Switch, etc. Malfunction

Take possible measures among the following in the order of 1 to 12. Each measure will improve noise reduction.

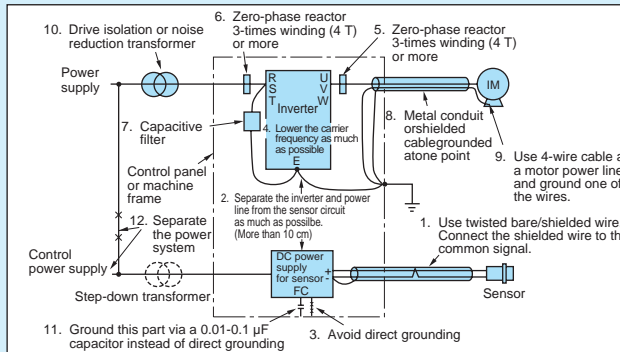

Corrective measures

1. Use twisted pair/shielded wire as a sensor signal line, and connect the shielded wire to common.
2. Separate the inverter and power line from the sensor circuit as much as possible. (More than 10 cm desirable)
3. Remove the grounding wire when the power supply for the sensor is grounded.
4. Lower the carrier frequency as much as possible. Up to approx. 10 kHz when low-noise operation is necessary.

5. Install a zero-phase reactor on the output side of the inverter. (Type: RC5078, RC9129)
6. Install an LC filter on the input side of the inverter. (Type: FS)
7. Install a capacitive filter on the input side of the inverter. (Type: 3XYHB-105104)
8. Use a metal conduit or shielded cable for power supply wiring.
9. Use 4-wire cable as a motor power line, and ground one of the wires.
10. Install a drive isolation or noise reduction transformer for the inverter power supply.
11. Ground the power supply for the sensor via a 0.01-0.1 μF \rightarrow (630V 0.1 μF)
12. Separate the inverter power supply from the sensor power supply system.

Connection of ty reactors and u capacitive filter

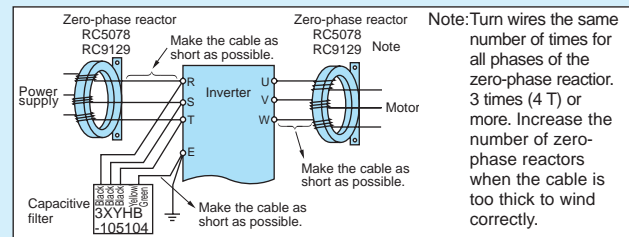

Continuous Operation Torque Characteristics

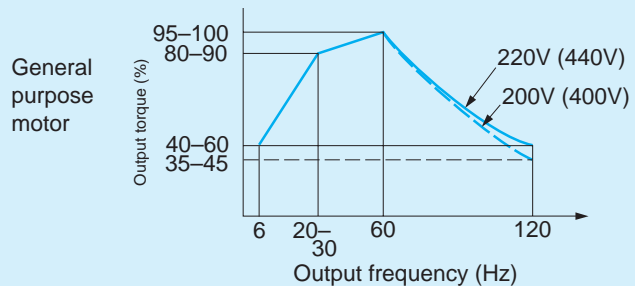
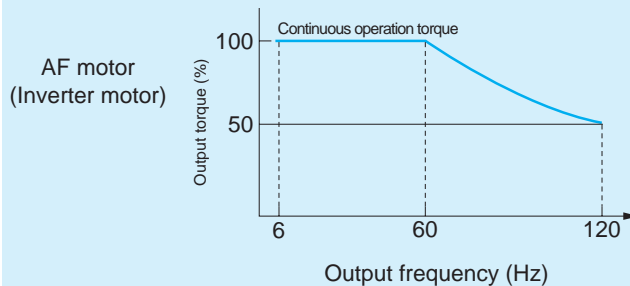

Motor Temperature Rise

When a general-purpose motor is used in variable-speed operation with an inverter, the temperature rise of the motor will be slightly greater than in cases where commercial power is used. The causes are shown below:

- Influence of output waveform** Unlike commercial power, the output waveform of an inverter is not a perfect sine wave, and contains higher harmonics. Therefore, the motor loss increases and the temperature is slightly higher.
- Reduction in the motor cooling effect during slow-speed operation** Motors are cooled by the fan on the motor itself. When the motor speed is reduced by an inverter, the cooling effect will decrease.

Therefore, lower the load torque or use an inverter motor to control temperature rise when the frequency is below the frequency of commercial power.

Life of Major Parts

The electrolytic capacitor, cooling fan, and other parts used for inverters are consumables. Their life substantially depends on the operating condition of inverters. When replacement is necessary, contact our dealer or service center.

■ Precautions for Application of Inverter

● Power supply

1. When the inverter is connected directly to a large-capacity power supply (especially in a 400 V line), excessively large peak will flow in, breaking the inverter unit. In such a case, install an AC reactor (option) on the input side of the inverter unit.
2. Install an AC reactor in the following cases as well.
 - 1) There is a possibility of surge voltage generated in the power supply system: When surge energy flows into the inverter, OV tripping may result.
 - 2) When a large-capacity thyristor Leonard or other phase control units are installed
3. When the inverter is operated by a private power generator, secure a sufficiently large generation capacity for the inverter kVA in consideration of the influence of higher harmonic current on the generator.

● Installation

1. Do not install the inverter in places with poor environmental conditions subjected to dust, oil mist, corrosive gas, or inflammable gas.
2. In places where there is suspended matter in the air, install the inverter inside a "closed-type" panel to prevent entry of suspended matter. Determine the cooling method and dimensions of the panel so that the ambient temperature around the inverter will be lower than the allowable temperature.
3. Vertically install the inverter on a wall. Do not install it on wood or other inflammable products.

● Handling

1. Do not connect the output terminal UVW of the inverter to the power supply; otherwise the inverter will be broken. Carefully check the wiring for correct arrangement before turning on the power.
2. It takes some time for the internal capacitors to discharge completely after the power is turned off. Check that the charge lamp on the printed circuit board is OFF before inspection.

● Operation

1. Do not start and stop the inverter frequently by means of an electromagnetic contactor (MC) installed on the input side of the inverter; otherwise failure of the inverter will result.
2. When more than one motor is operated by one inverter, select the inverter capacity so that 1.1 times the total rated current of the motors will not exceed the rated output current of the inverter.
3. When an error occurs, the protective function is activated and the inverter trips and stops operation. In that case, motors will not stop immediately. When emergency stop is desired, use mechanical brakes as well.
4. The acceleration time of the motor is subject to the inertial moment of the motor and load, motor torque, and load torque.
 - 1) When the acceleration time setting is too short, the stall prevention function is activated, and the setting time is elongated automatically. For stable acceleration and deceleration, set longer time so that the stall prevention function will not be activated.
 - 2) When the deceleration time is too short, the stall prevention function is activated or OV tripping will result. Set longer deceleration time or install a braking unit/braking resistor.

● Setting

The HF-320 α inverter is set in the V/F constant control mode before shipment from our factory. When control without a sensor is necessary, change the setting.

■ When Operating 400 V Class Standard Motor

When the inverter is used to drive a standard motor (general-purpose motor), a high carrier frequency type inverter (e.g. IGBT) requiring high input voltage (more than 400 V) is necessary. When the wiring distance is long, the dielectric strength of the motor must be taken into consideration. Contact us in such cases.

Terminology

- Control without sensordVector control is conducted without using a sensor (PG, etc. for speed feedback control). This method improves the motor speed accuracy and torque characteristics from the low to high frequency band better than the V/F control does. Since the control is based on the motor constant, this control method is applicable when one motor is connected to one inverter.
- V/F controlThe V/F (voltage/frequency) is maintained constant for a motor. The motor speed accuracy and torque characteristics are inferior to the control without a sensor that stabilizes the magnetic flux. However, unlike the control without a sensor, more than one motor can be connected to one inverter.
- Torque boostThe loss of output torque due to the voltage drop inside the motor is compensated for under the V/F control. Under the control without a sensor, the torque boost is automatically controlled according to the load, so boost setting is unnecessary.
- Auto-tuningThe inverter automatically measures and saves the motor constant that is necessary for control without a sensor. The motor constant of our motors are already saved in the inverter. Just select the model of the motor, and auto-tuning is unnecessary. (Tune the wiring resistance when it is long.)
- Energy-saving modeEnergy loss is controlled by reducing the motor flux when the load is light. The parameter Pt is used for setting.
- Base frequencyBoundary point between the constant torque characteristic area and constant output characteristic, which is usually 50 or 60 Hz.
- Stall preventionThe output frequency is controlled in order to prevent a stall (loss of motor speed) and overcurrent error even if the output current increases when the acceleration time is short or a load is heavy. When this function is activated or overcurrent is generated, it is necessary to reexamine the capacity of the motor and inverter.
- Electronic thermal relayA function identical to the thermal relay for protection of the motor from overloading is incorporated in the inverter. Since the electronic thermal relay is not affected by high-frequency, it protects more accurately than a thermal relay. However, when more than one motor is connected to one inverter, install a thermal relay individually for respective motors. The characteristics of the electronic thermal relay is slightly different from that of thermal relays because the condition of temperature around the motor is not included.

■ Warranty Policy on Inverter

Warranty period	The warranty shall be 18 months from date of shipment or 12 months after initial operation, whichever is shorter.
Warranty condition	In the event that any problem or damage to the Product arises during the "Warranty Period" from defects in the Product whenever the Product is properly installed and combined with the Buyer's equipment or machines maintained as specified in the maintenance manual, and properly operated under the conditions described in the catalog or as otherwise agreed upon in writing between the Seller and the Buyer or its customers; the Seller will provide, at its sole discretion, appropriate repair or replacement of the Product without charge at a designated facility, except as stipulated in the "Warranty Exclusions" as described below. However, if the Product is installed or integrated into the Buyer's equipment or machines, the Seller shall not reimburse the cost of: removal or re-installation of the Product or other incidental costs related thereto, any lost opportunity, any profit loss or other incidental or consequential losses or damages incurred by the Buyer or its customers.
Warranty exclusion	Notwithstanding the above warranty, the warranty as set forth herein shall not apply to any problem or damage to the Product that is caused by: <ol style="list-style-type: none"> 1. Installation, connection, combination or integration of the Product in or to the other equipment or machine that rendered by any person or entity other than the Seller; 2. Insufficient maintenance or improper operation by the Buyer or its customers such that the Product is not maintained in accordance with the maintenance manual provided or designated by the Seller; 3. Improper use or operation of the Product by the Buyer or its customers that is not informed to the Seller, including, without limitation, the Buyer's or its customers' operation of the Product not in conformity with the specifications; 4. Any problem or damage on any equipment or machine to which the Product is installed, connected or combined or any specifications particular to the Buyer or its customers; 5. Any changes, modifications, improvements or alterations to the Product or those functions that are rendered on the Product by any person or entity other than the Seller; 6. Any parts in the Product that are supplied or designated by the Buyer or its customers; 7. Earthquake, fire, flood, salt air, gas, lightning, acts of God or any other reasons beyond the control of the Seller; 8. Normal wear and tear, or deterioration of the Product's parts, such as the cooling fan bearings; 9. Any other troubles, problems or damage to the Product that are not attributable to the Seller.
Others	The Seller will not be responsibility for the installation and removal of the inverter. Any inverter transportation cost shall be born by both Seller and Buyer.

■ Warranty Policy on Repaired and Returned Products

Warranty period	The warranty shall be 6 months from date of repair and shipment.
Warranty condition	Warranty on repaired Product will apply only on the replacement parts used in the repair done or authorized by the Seller. All other aspects conform to the Warranty Conditions described in item 1.
Warranty exclusion	Please refer to Warranty Exclusions described in item 1.
Others	Please refer to Others deccribed in item 1.



30025 Alicia Pkwy #417, Laguna Niguel, CA 92677 USA
+1.949.218.4996 • www.LCIfurnaces.com