

THERMAL PROCESSING THEORY

6.1 Infrared Waves

Infrared waves form part of the electromagnetic spectrum. Electromagnetic waves with wavelengths from 0.78 μm to 1000 μm are called infrared waves. You are already familiar with electromagnetic waves of different wavelengths. Microwaves, X-rays, radio waves and visible light are all electromagnetic waves. Infrared waves produced inside the furnace lie predominately in the near and medium infrared range with wavelengths ranging between 0.5 and 3.0- μm .

When using infrared lamps, higher heat-lamp temperatures emit higher radiant energy. This elevated energy translates to a shorter electromagnetic wavelength of emitted IR radiation. While the IR waves of a heat lamp come from a continuous range of wavelengths, the **dominant wavelength** (λ_{dom}) as given by Plank's distribution principle is the wavelength transmitted with the highest occurrence. So for a given temperature, only one λ_{dom} exists. See Figure 6-1 Dominant Wavelength Graph below.

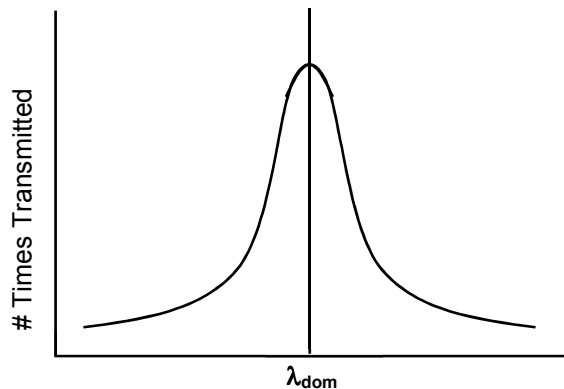

Figure 6-1 Dominant Wavelength Graph

The relationship between heat-lamp filament temperature T and λ_{dom} is given by the fixed relationship:

$$\lambda_{\text{dom}} \mu\text{m} = \frac{2897 \mu\text{m}\cdot\text{K}}{T \text{ K}}$$

To convert from degrees Celsius ($^{\circ}\text{C}$) to Kelvin (K) add 273 to the Celsius temperature value.

For example:

At 1000 $^{\circ}\text{C}$ the respective material dominant wavelength is:

$$T = 1000^{\circ}\text{C} + 273$$

$$T = 1273 \text{ K}$$

Substituting back into the given equation:

$$\lambda_{\text{dom}} = 2897 \mu\text{m}\cdot\text{K} / 1273 \text{ K}$$

$$\lambda_{\text{dom}} = 2.28 \mu\text{m}$$

6.2 Infrared Heating

Infrared (IR) heating is electromagnetic radiation emitted from the surface of IR lamps or emitters. Thermal radiation is generated when heat from the movement of charged particles within atoms is converted to electromagnetic radiation. In the furnace, radiant heating from IR lamps provides heat directly to objects without first heating the surrounding air. IR waves excite molecules within a substance (product) thus generating heat, but pass generally undisturbed through the surrounding atmosphere. Other substances such as glass, ceramics and some organic materials are also transparent to IR waves. Objects suspended in these media can, therefore, be heated directly by IR waves without directly heating the supporting media.

Not all heating in the furnaces occurs via direct IR radiation. The belt and air inside the furnace are heated via the IR lamps. Also edge heaters (resistance heaters installed along the furnace length) can introduce heat into the furnace. Your product also acquires heat from the edge heaters, conveyor belt and surrounding heated gas in the chamber via **conduction**.

The amount of direct heating via IR radiation is determined by three factors:

1. The level of IR radiation emitted from the heat lamps.
2. The amount of IR absorbed by a product.
3. The level of edge heat introduced into the furnace

If you know the **resonant frequency** of a particular substance, matching the furnace dominant wavelength the product resonant frequency ensures maximum energy transfer via IR radiation. In most cases, rapid product heating can be achieved more efficiently through frequency matching rather than with temperature increases.

6.2.1 Advantages of IR Heating

Heating via conduction and convection operates by transferring heat to object surfaces. Heat is then transferred from the surface to the layers beneath. Heat transfer, however, is not uniform, causing temperature differences and unequal expansion across an object. The unequal expansion due to the uneven heating is called thermal stress and can cause objects to fracture called thermal shock.

IR radiation heats molecules below an object's surface and allows for more uniform heat distribution than can be provided by conduction and convection heating alone.

Rapid heat up time is also achieved with IR technology due to the high energy-transfer rate of IR waves. The speed of conduction and convection heating is proportional to the temperature difference between the object and heating environment, whereas the speed of IR heating is proportional to the difference between the fourth powers of the object and environment temperatures.

For example:

Suppose the temperatures of an object were 100°C.

If a convection heating furnace were heated to 500°C, the proportional difference would be

$$500 - 100 = 400$$

If an IR furnace were heated to 500°C, the proportional difference would be

$$500^4 - 100^4 = 6.25 \times 10^8 - 1.00 \times 10^8 = 6.24 \times 10^8$$

Other factors such as the emissivity of objects are taken into account when calculating energy transfer rates.

6.3 Thermal Process

The **thermal process** is the idealized process description for a particular product as it passes through the process section, including the product temperature profile and process environment. When establishing the thermal process, a consistent temperature profile is just as important as establishing the correct process environment.

Each dissimilar product that passes through a continuous belt Infrared furnace will likely utilize a different thermal process. Engineering design and empirical testing are the best methods of achieving the best thermal process.

6.4 Temperature Profiling

The proper thermal process is usually verified by performing a temperature profile. A temperature profile represents multiple temperature measurements taken at close intervals over a period of time through the length of the furnace. Product passing through the furnace go through a set of temperatures known as a temperature profile.

Notice in Figure 6-2 that the green horizontal lines define the setpoint temperatures, yet the thermocouple readings do not reach the actual setpoint temperature inside each zone. Also notice that the product peak temperature may be achieved well inside the cooling section.

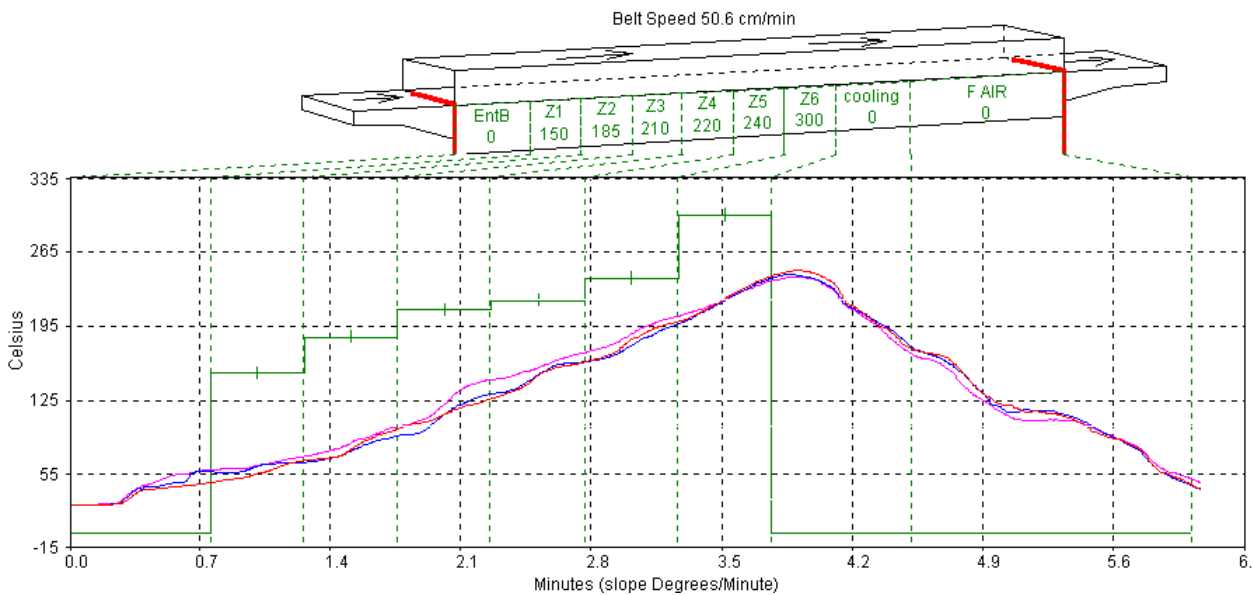

Figure 6-2 Temperature Profile

The temperature profile will be affected by the product material, mass and process gas. For example, a furnace with a controlled atmosphere cooling module installed can cool the product while in a pure nitrogen gas environment. The same temperature profile could be achieved with a forced-air cooling module, but could subject the product to a potentially hazardous oxidizing environment at elevated temperatures.

Prior to shipment, all furnaces undergo a temperature profile test. In this test, typically one or three (on furnaces with 15-inch or wider belt) thermocouples are sent through the furnace located on sample product on the conveyor belt at the center and, if three are used, one each side. All furnace zones are programmed to produce the furnace owner’s prescribed setpoint temperature and allowed to reach steady state. The thermocouple readings are expected to remain within 5% of one another. While this test is performed at the factory, it should also be performed at startup and periodically thereafter to assure that the desired temperature profile can be maintained.

6.4.1 Profiling Responsibilities

The process engineer must set the furnace process parameters to achieve the desired temperature profile with the product. To do this, the engineer must have an idea of the process cycle of the product and the important process parameters and limitations. Looking again at the temperature profile from Figure 6-2 Temperature Profile, six zones are visible labeled Z1 – Z6. Depending upon the configuration of the furnace, fewer or more zones may be present. Initially, temperature profiles must be recorded from temperatures measured inside the furnace.

6.4.2 Profile Specification

In general, the temperature profile is defined by a combination of the following parameters:

- a. Heating Rate: The rate of increase of temperature from room temperature.
- b. Dwell/Hold Time: The time the product remains above a certain temperature or range of temperatures.
- c. Second Heating Rate: The rate of increase of temperature from the temperature reached during the hold time (if required).
- d. Second Hold Time: Dwell/Hold time for 2nd heating (if required).
- e. Peak Temperature: The maximum temperature reached with a +/- range and time at peak.
- f. Cooling Rate: The rate of decrease of temperature to a lower/critical temperature.
- g. Product Exit Temperature: As required.

If across the belt temperature distribution is a critical factor, use of three thermocouples attached in a similar fashion in the same line across the belt can reveal the temperature stratification during furnace processing.

If the parts are of great thickness as in a brass forging part, two thermocouples can be used to measure the temperature differences at different locations on the sample part.

For production work, the required specification must be achievable at a single speed setpoint within the specified furnace speed range. In general, the speed range depends on the factory gearing for the size and type of furnace and the specified requirements. Many sets of belt speeds and temperature settings can meet a given set of profile specifications. Furthermore, higher belt speeds can result in greater temperature deviations and lower consistency from the desired temperature profile. Also higher speeds shortens the cooling retention time and the parts may exit the furnace too hot.

6.4.3 Basic Profiling Variables

The two most influential and basic variables in setting up a temperature profile are:

- Retention Time: The time required to pass through the process section. Retention time is influenced by belt speed and zone temperature setpoints.
- Temperature Setpoints: Determines the energy level in each zone.

The combination of the time-temperature exposure of the product determines the temperature profile. The temperature settings in each zone set the heating rate and hold times of the product.

A third and less influential factor in the temperature profile is:

- Flow Meter Settings: Controls the rate of gas flow through the process section. Can influence heating and cooling rates and furnace IR stability.

If the furnace is equipped for a controlled atmosphere, this will be an important factor to consider. Gas flow and flow meter settings is addressed in detail in Sections 5.1.3 Process Gas Inflow **Error! Reference source not found.** and 5.1.4 Balancing the Gas Flow.

6.4.4 Types of Profiles

In most processes, two kinds of temperature profiles exist:

Equilibrium (flat) profile applications:

- Annealing
- Brazing
- Die-attachment processes
- Drying/Curing of polymeric products
- Glass or metal/solder sealing of IC packages
- Hybrid thick film and PTF firing

Non-Equilibrium (peaked/spiked) profile applications:

- Cerdip lead-frame attachment
- Solar cell firing processes
- Solder reflow attachment

Most microelectronic and semiconductor thermal processes fall into one of the above categories, or some combination of the two. Set the furnace parameters according to the type of process that will be used with the furnace.

Examples of the two fundamental types of profiles are illustrated in **Error! Reference source not found.** and Figure 6-4**Error! Reference source not found.**

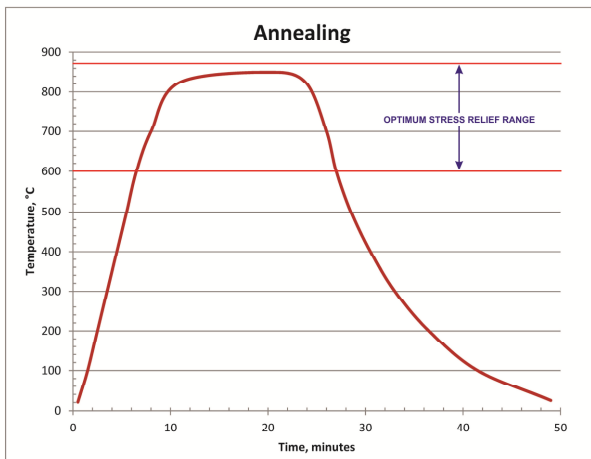

Figure 6-3 Equilibrium Profile

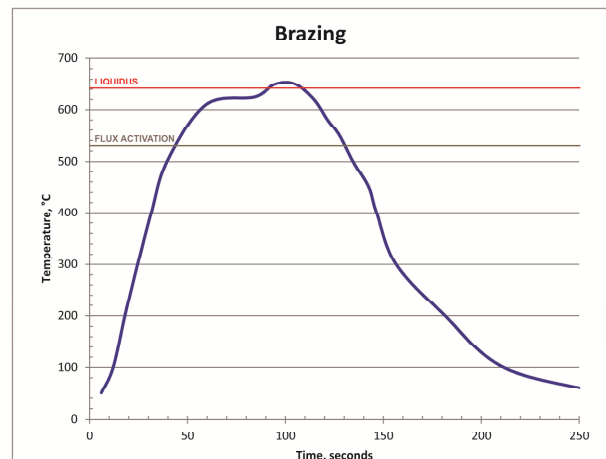

Figure 6-4 Non-equilibrium profile

6.4.5 Profiling Apparatus

A typical setup for profiling an LA-306 infrared furnace is depicted in Figure 6-5 and includes a computer and data logger positioned at the entrance of the furnace. For profiling, a type K thermocouple is placed on the surface of a part or representative sample which can be placed on the belt or in a parts boat. The thermocouple is plugged into a data logger connected to the computer. Figure 6-6 shows a close-up of a high speed high temperature type K thermocouple, a wire basket or parts boat, and a DataPaq Q18 data logger. As the part travels through the furnace, the computer graphs the temperature as a function of time and distance traveled.

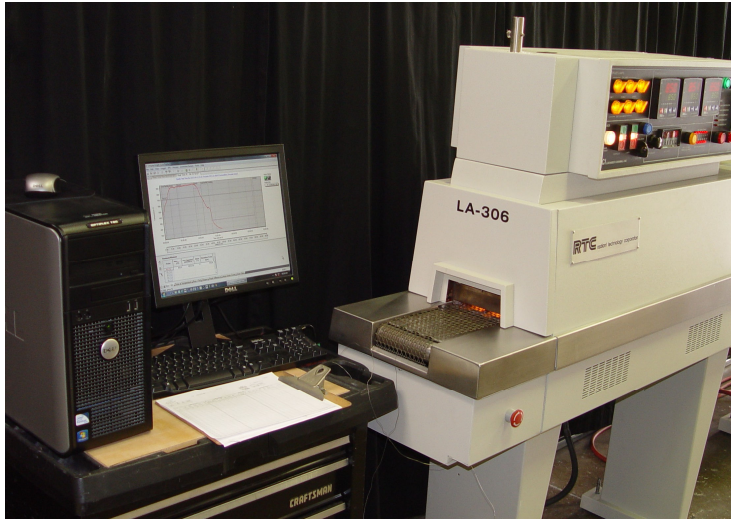

Figure 6-5 Temperature Profiling Apparatus

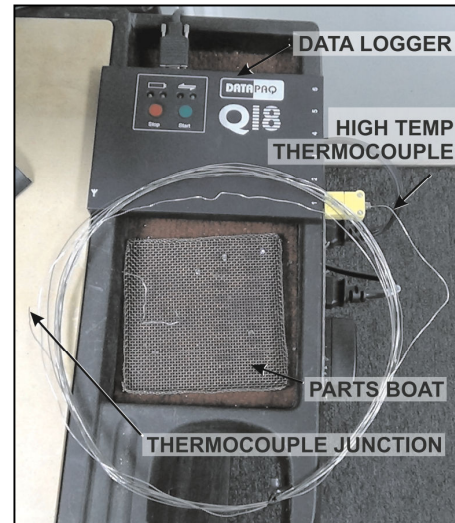

Figure 6-6 Data Logger

To produce a temperature profile, the following components are needed:

- Thermocouple
- Data Logger
- Sample part
- Computer

A. Thermocouple Wires

K-Type thermocouples are recommended.

Depending upon operational temperatures, use a properly rated thermocouple for accurate readings. For temperatures above 300°C, we recommend the use of ultra-thin high speed type K thermocouples. Make sure exterior sheath is grounded to furnace frame.

Use one thermocouple for centerline profiling or three for across-the-belt profiling.

B. Data Loggers

A data logger or temperature data collection device. Examples are:

- Chart recorder
- DATAPAQ data logger (Q18 or similar)
- KIC temperature profiling kit
- MOLE/SuperMOLE data logger

Figure 6-6 shows a DataPaq Q18 six-channel data logger with one high temperature thermocouple attached to channel 1.

Another data collection method involves sending a data logger down the belt inside an insulated enclosure. A short thermocouple is connected to the data logger through a sealed opening in the enclosure. The data logger collects the data for later transfer to a computer for graphing and analysis.

C. Sample Part

The part can be an actual production part, or something of similar material, mass, size and shape. The closer the sample is to an actual production part, the more representative the results will be. If parts boats or carriers are to be used in production, use a similar boat for the test. Figure 6-7 and Figure 6-8 depict different samples with high temperature thermocouples in position.

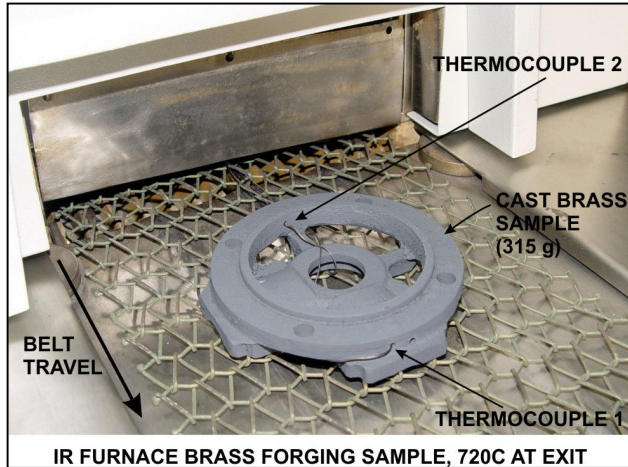

Figure 6-7 Brass Forging Sample With 2 thermocouples

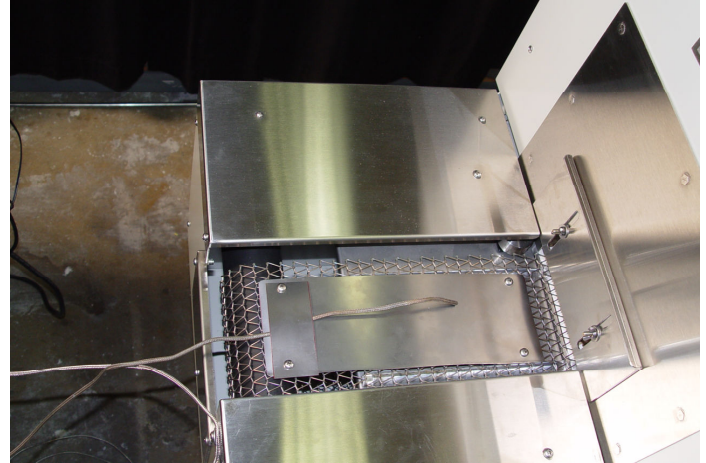

Figure 6-8 Metal Plate Sample with Wire Sheath Type K Thermocouple

6.4.6 Profiling Procedure

A. Operate furnace to steady state or READY.

B. Connect the thermocouple to the part and place on Load table.

1. Below temperatures of 300°C, the thermocouple can be taped with Kapton tape to a test specimen. Repeat testing may require new tape for accurate results.
2. Above 300°C, the thermocouple sensor can be cemented onto a test specimen if direct contact is not otherwise possible. In cases where the product of interest is not readily available, the thermocouple may be placed inside a small length of ceramic tube called a bead or other piece of material similar in shape and mass to the actual product.

C. For real time viewing, ready profiling software on the computer.

D. Place sample on belt. As thermocouple junction in the part passes furnace entrance, start data logger (click on start button on computer screen).

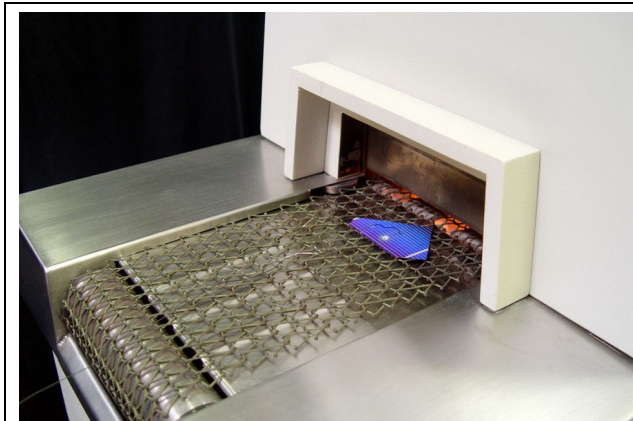

Figure 6-9 Silicon Wafer Entering Furnace

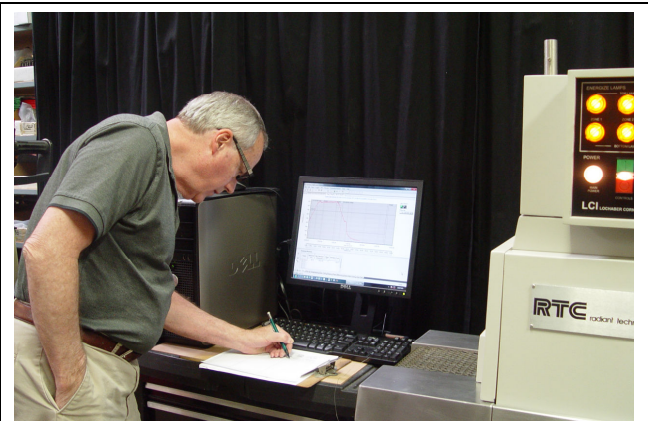

Figure 6-10 Recording Setpoints

Chapter 6

- E. Place sample on belt. As part passes furnace entrance (Figure 6-9Error! Reference source not found.), start data logger.
- F. Record temperature setpoints and process gas flowmeter setpoints in a log (Figure 6-10)
- G. As thermocouple junction passes exit of furnace, stop data logger.

Note: If the start and the stop times coincide with the furnace entrance and exit, the actual belt speed can be verified in the profiling software and graph.

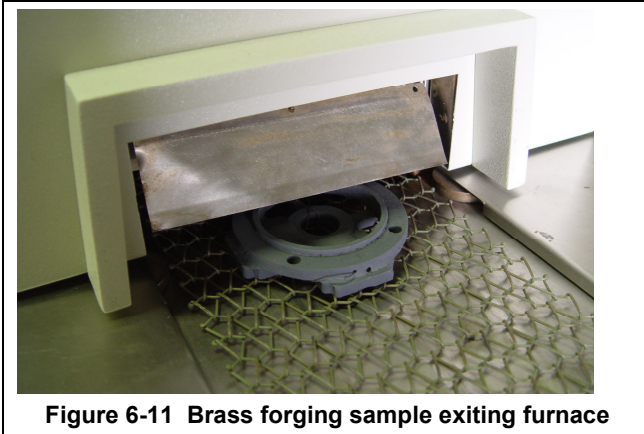

Figure 6-11 Brass forging sample exiting furnace

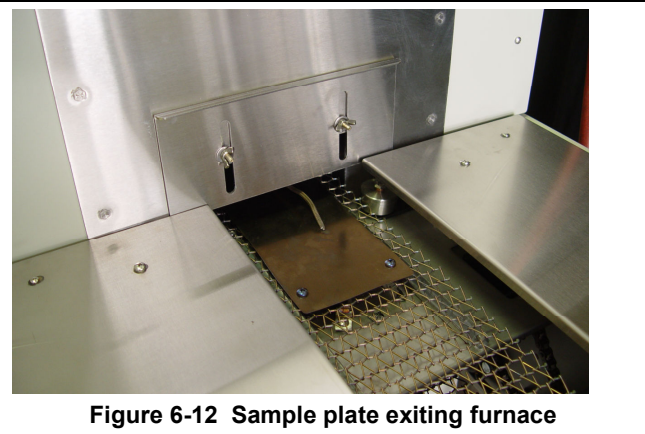

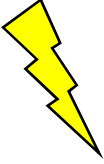
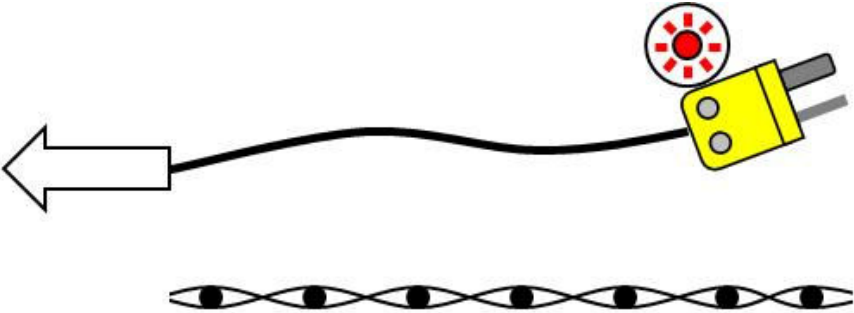

Figure 6-12 Sample plate exiting furnace

6.4.7 Safety Tips

	<p>DANGER: When using metal shielded thermocouple wires inside a furnace, electrostatic energy may collect on the wires. Properly ground the shielding material to the furnace chamber by wrapping a wire around the sheath and attaching one end to an unpainted portion of the furnace cabinet</p>
<p>DANGER:</p> 	<p>Extreme caution must be taken when pulling thermocouple wires through the process section. Connectors may bounce inside the chamber and break a lamp exposing the handler to high voltage and current, which could cause serious injury or death.</p> 

6.4.8 Equilibrium Profile Settings

For equilibrium profiles (flat temperatures profiles), set a belt speed that will result in at least a 6-10 minute dwell time inside the heating chamber. The following table shows some belt speeds for various heating chamber lengths.

Table 6-1 Equilibrium Belt Speed Recommendations					
Heating Chamber Length		Dwell Time			
(inches)	(cm)	6 minutes		10 minutes	
		(in./min)	(cm/min)	(in./min)	(cm/min)
30	76	5	12.7	3	7.6
60	152	10	25.4	6	15.2
90	229	15	38.1	9	22.9
120	304	20	50.8	12	30.4

For across-the-belt temperature profiles, set the belt speed to a minimum. The slow rate of the conveyor belt will result in a larger number of recorded temperature readings. A slower rate increases the resolution of the temperature profile and can reveal more information about temperature uniformity and consistency.

Set all zone temperatures to the desired peak temperature plus 5°C.

If edge heaters are installed, a setpoint of 30% power is a good starting point. Also, for edge heat, allow a few minutes to pass between setting adjustments, as the nickel chromium edge heat wires do not respond as quickly as the IR heat lamps.

If faster heating rate is desired with a longer dwell time at the peak temperature, increase the first 1-2 zone temperature setpoints by about 10-20% of the peak temperature. The heating rate will be higher at the start, while the remaining zones will maintain the temperature of the product at the peak temperature.

A slow belt speed will allow the temperature to reach the peak temperature within the first 1-2 zones. The rest of the heating chamber will hold the temperature for the remainder of the profile.

- Record the temperature and observe the results.

If the desired temperature and hold time is not achieved, begin tuning the belt speed and zone setpoint temperature variables. The following are some guidelines:

For faster initial heating rates, try one of the following:

- Lower the belt speed
- Raise the first 1-2 zone temperature setpoints

For slower initial heating rates:

- Raise the belt speed
- Lower the first 1-2 zone temperature setpoints

For faster belt speeds:

- Raise the belt speed 5%
- Increase zone 1-2 setpoint temperatures by 7%

For slower belt speeds:

- Lower the belt speed 5%
- Decrease zone 1-2 setpoint temperatures by 7%
- Record a new temperature profile

Go back and retune as necessary until the desired temperature profile is achieved.

6.4.9 Profiling Results – Typical Curves

Following are examples of actual LA-306 profiles run at the factory on different machines with product samples for a wide range of applications. Figures 9-13, 9-15 and 9-16 were performed on LCI LA-306 models. Figures 9-14, 9-17 and 9-18 were performed on LCI retrofitted RTC LA-306 furnaces. The LA-306 is a compact laboratory 3-zone furnace that can be used for modelling the behavior of a much larger furnace.

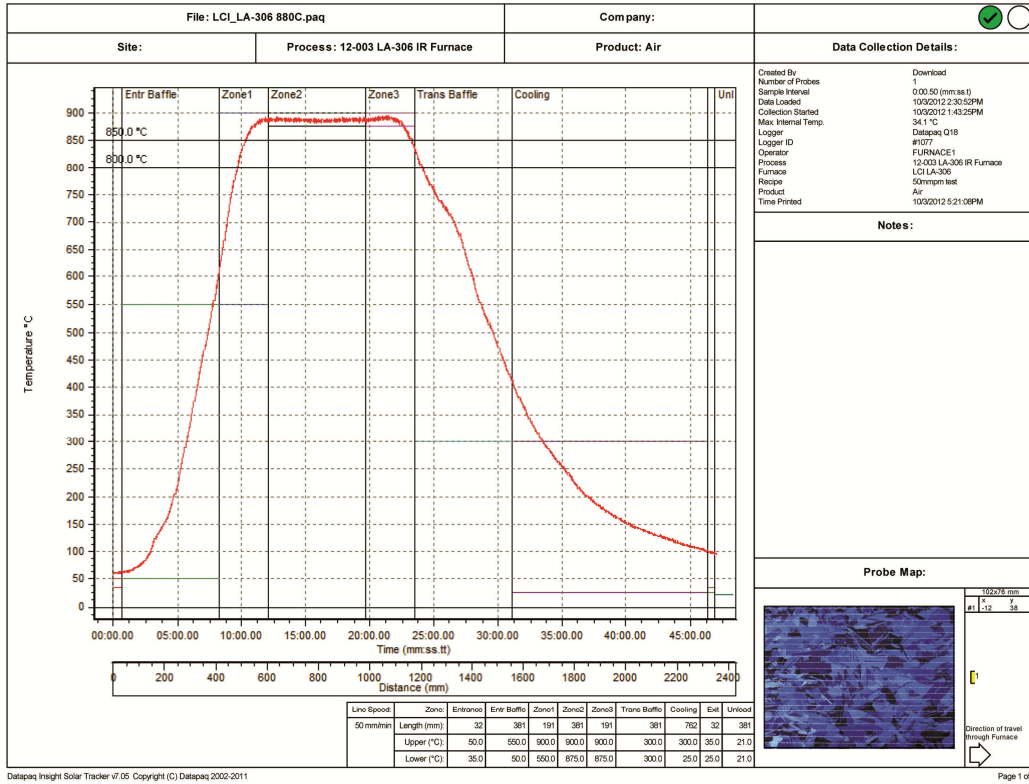

Figure 6-13 880 °C Annealing profile

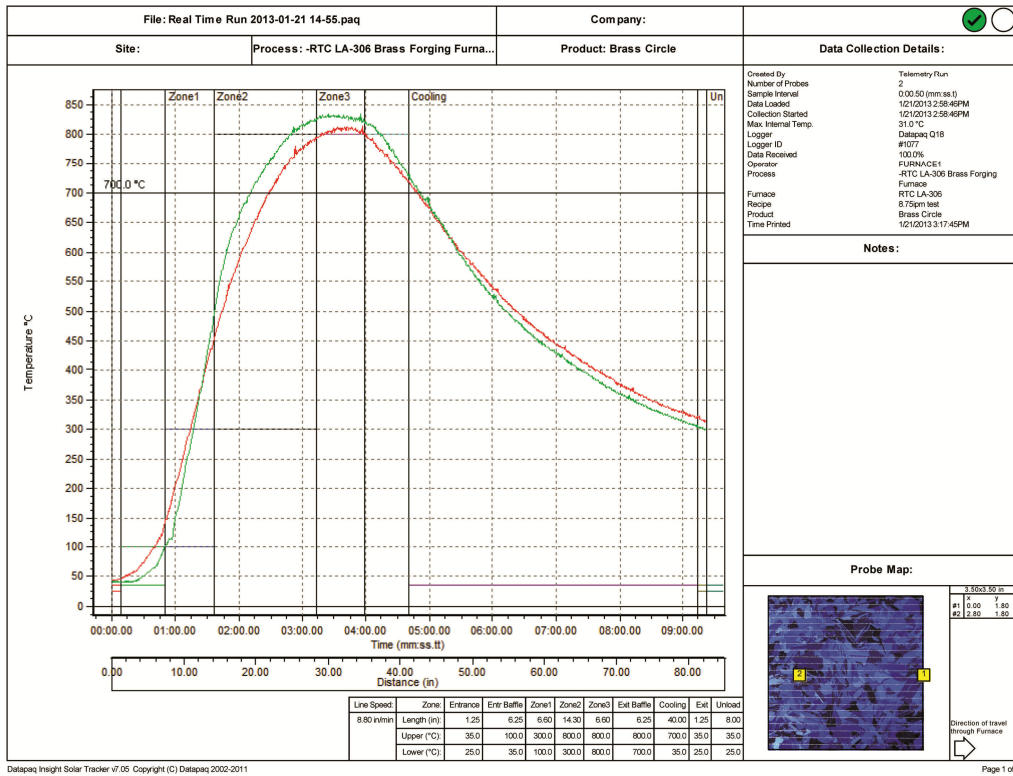

Figure 6-14 880 °C Brass Forging profile

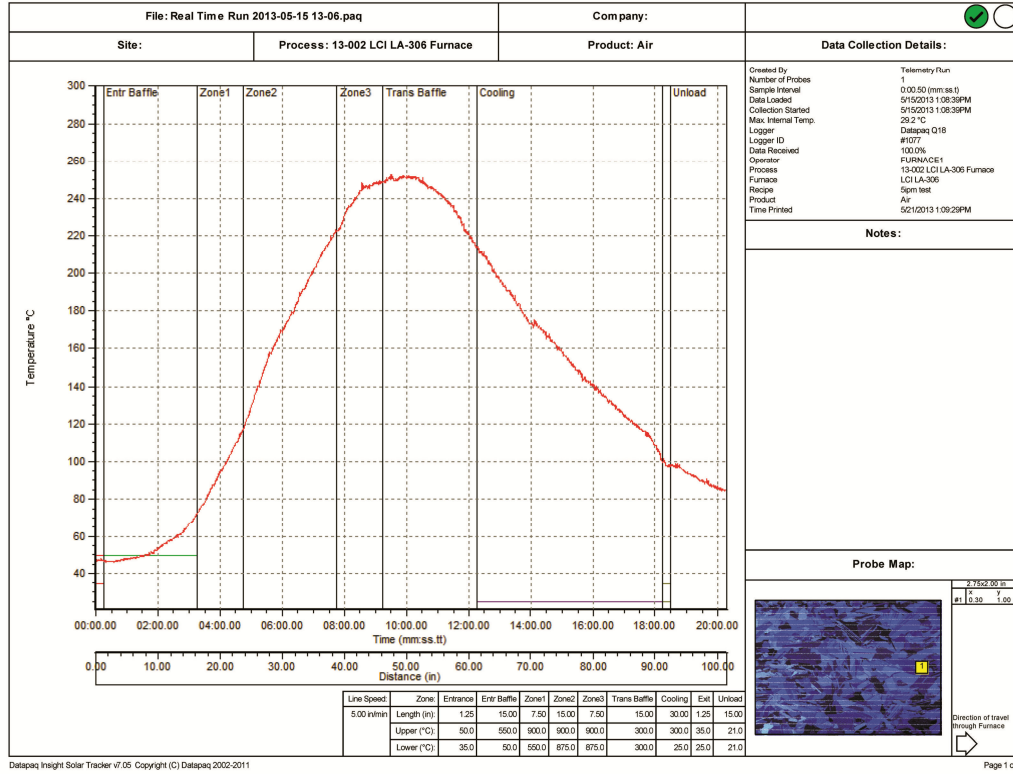

Figure 6-15 250 °C Curing Profile

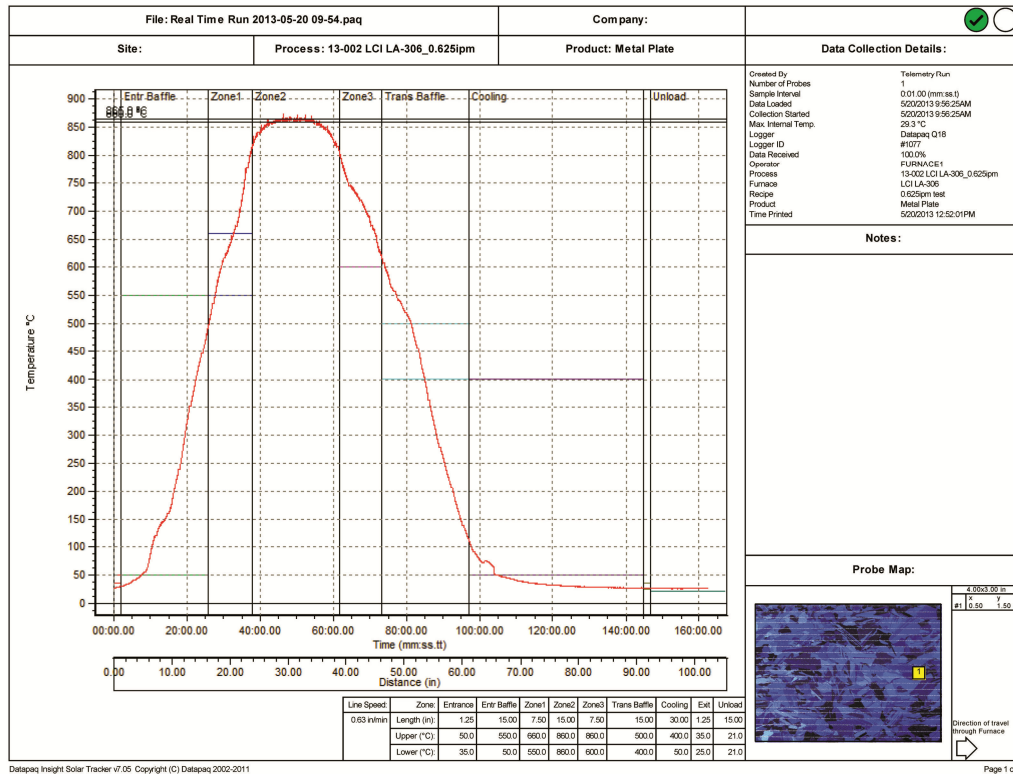

Figure 6-16 860 °C Thick Film profile

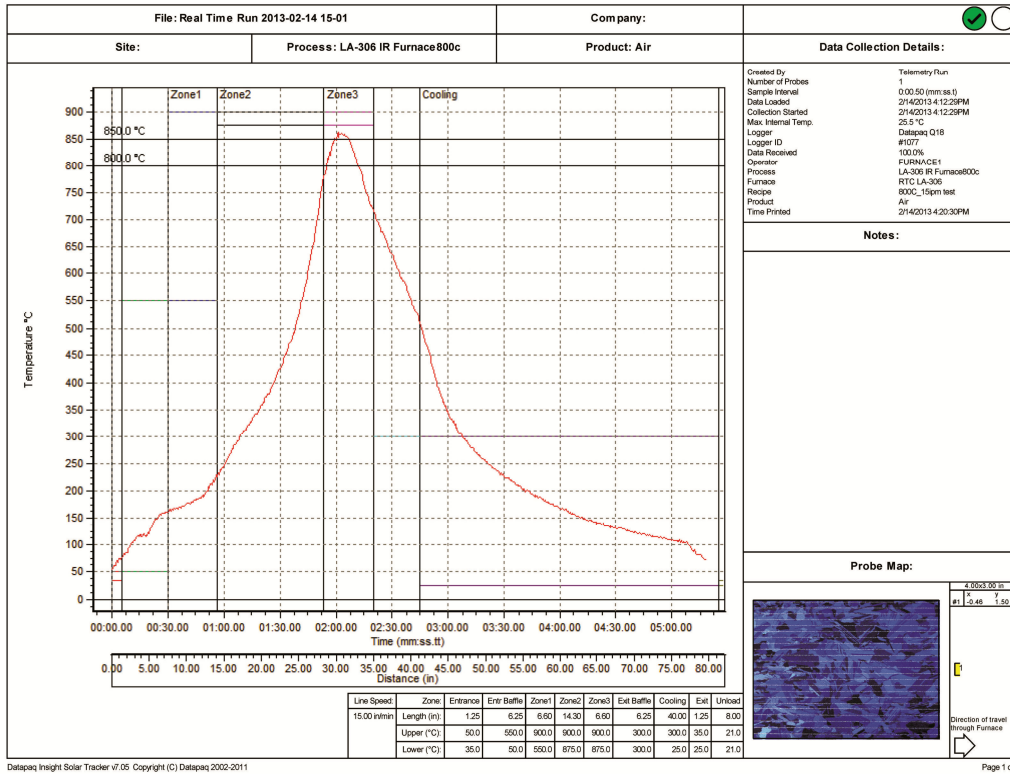

Figure 6-17 860 °C Spike profile

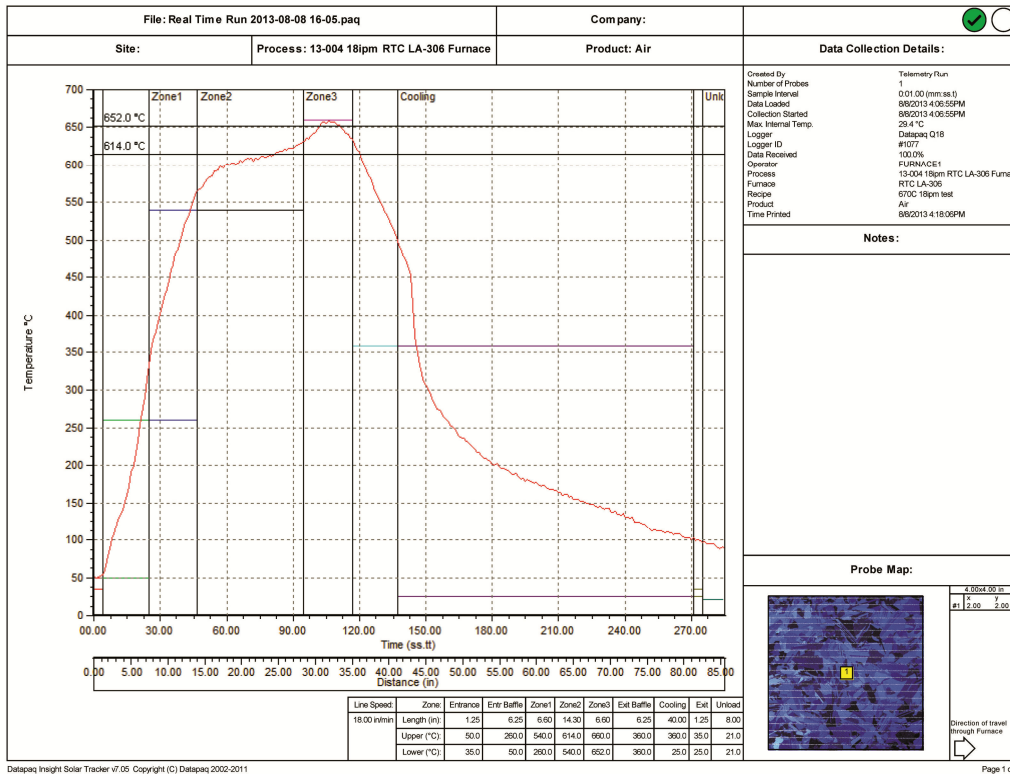

Figure 6-18 652 °C 1205 Brazing profile