

# FURNACE EQUIPMENT

Description of the SMD-615 infrared furnace basic thermal process elements, standard and optional hardware and their functions. Refer to section 1.6 for optional equipment description and operation.

## 1.1 Furnace Description

The SMD-615 is a computer controlled near-infrared, conveyor belt furnace for laboratory and production thermal processing in the range of 100-600 °C in a controlled atmosphere, free of outside contamination. Your furnace is configured for a maximum 600 °C temperature operation. Process gas may be clean dry compressed air (CDA), nitrogen (N<sub>2</sub>), Forming Gas (FG) and/or another inert gas. Tri-gas and dual gas furnaces may use CDA with N<sub>2</sub> in the furnace process zones; or N<sub>2</sub> and a second gas such as FG (pre-mixed N<sub>2</sub>/H<sub>2</sub>) or another type non-combustible gas reducing gas injected into the heating chamber.

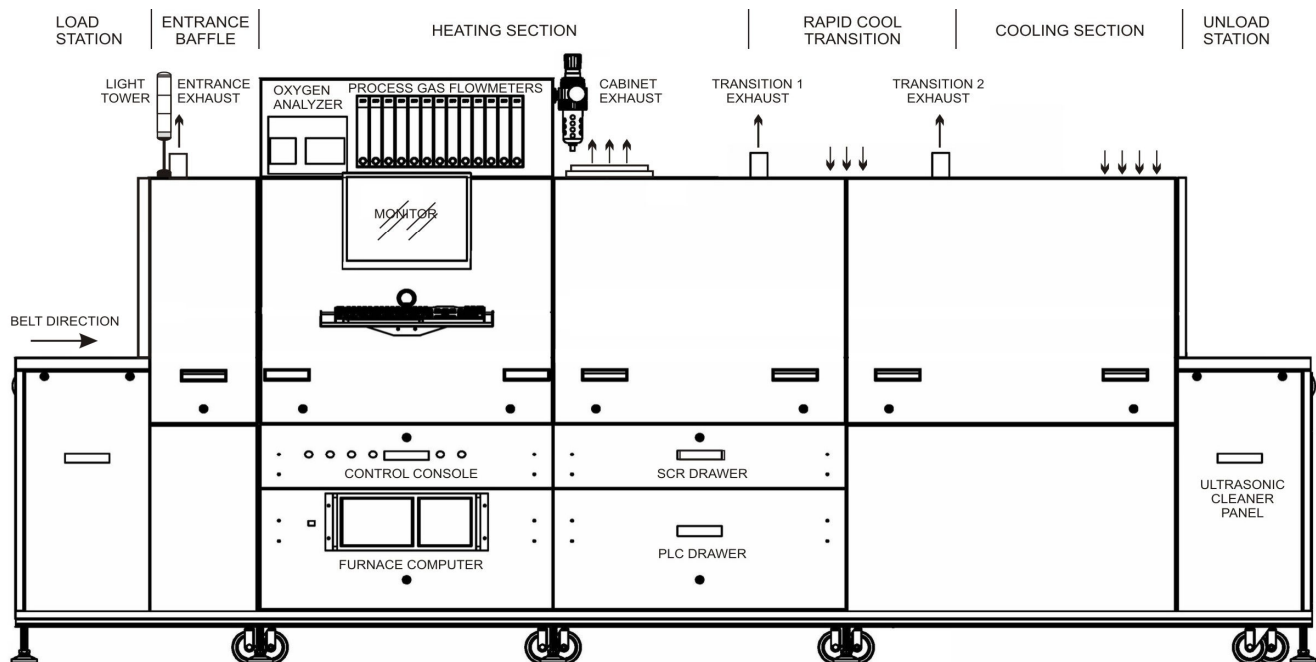

Figure 1-1 SMD-615 Furnace Front

The SMD-615 furnace transports product on a 460 mm (18-inch) wide belt. In the standard design the chamber clearance above the belt is 50 mm (2 inches). Optionally the furnace can be ordered with 25 mm (1-inch) or 100 mm (4-inch) vertical clearance above belt. SMD-615 furnaces feature a hermetically sealed heating chamber permitting control of the furnace chamber process environment. Baffle sections before and after the heating section contain curtains that hang down to just above the belt to further isolate the furnace chamber from the room atmosphere and from the cooling section.

The SMD-615 can process surface mount devices, substrates, wafers, PCBs, metal, ceramic, glass or polycarbonate parts for electronic package sealing, thermo-setting polymer curing, reflow soldering, copper and hybrid/thick film firing, brazing, tempering and metal sintering applications, or almost any kind of general thermal processing requiring precision temperature control in a controlled atmosphere environment.

The SMD-615 can also be used for precise curing of coatings on optical lenses, advanced thin film crystalline silicon, cadmium telluride (CdTe alloys) and certain copper indium diselenide (CIS-alloys) as well as many other production applications.

# Section 1

## 1.2 Furnace Views

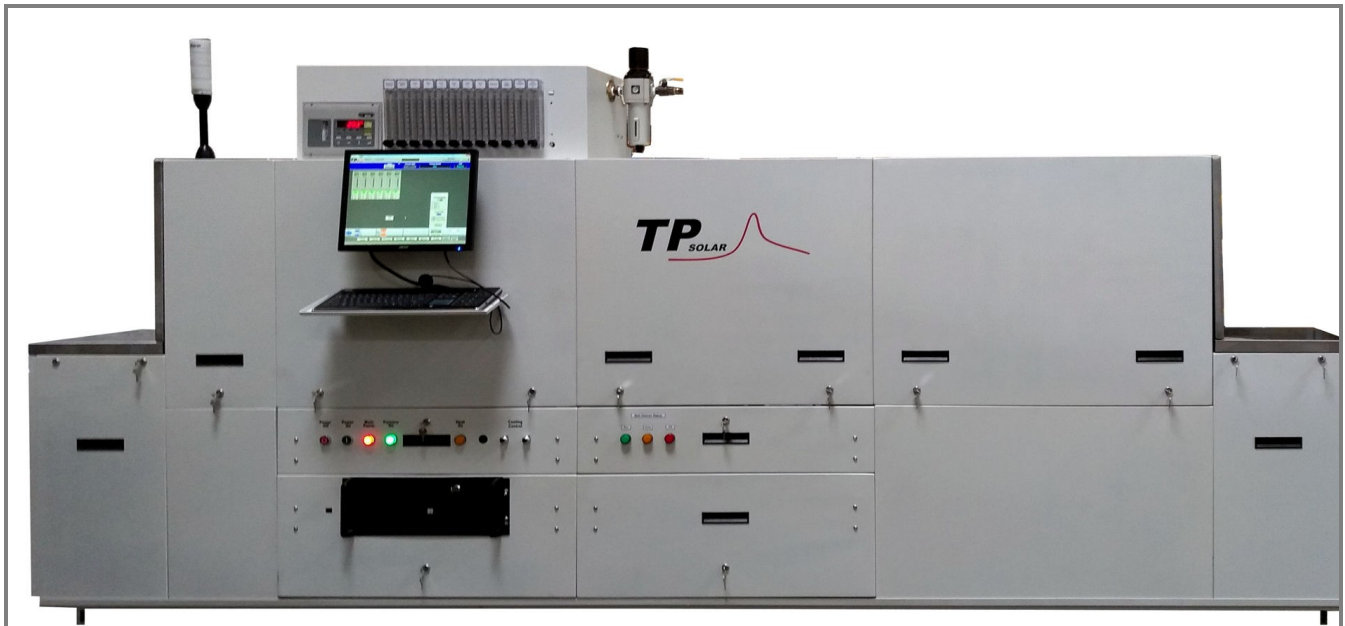

Figure 1-2 SMD-615 Furnace Front Elevation



Figure 1-3 Entrance Elevation

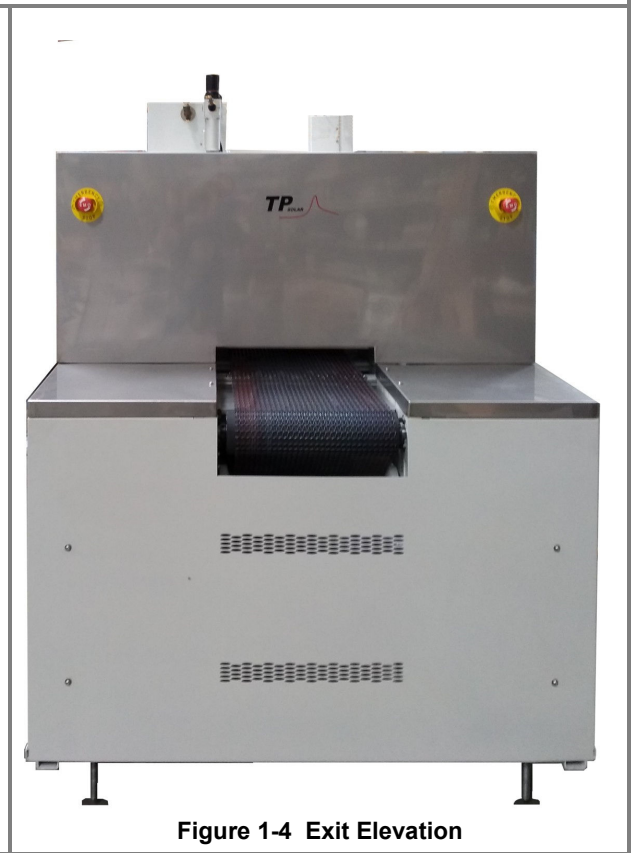

Figure 1-4 Exit Elevation



Figure 1-5 Front, Panels Off

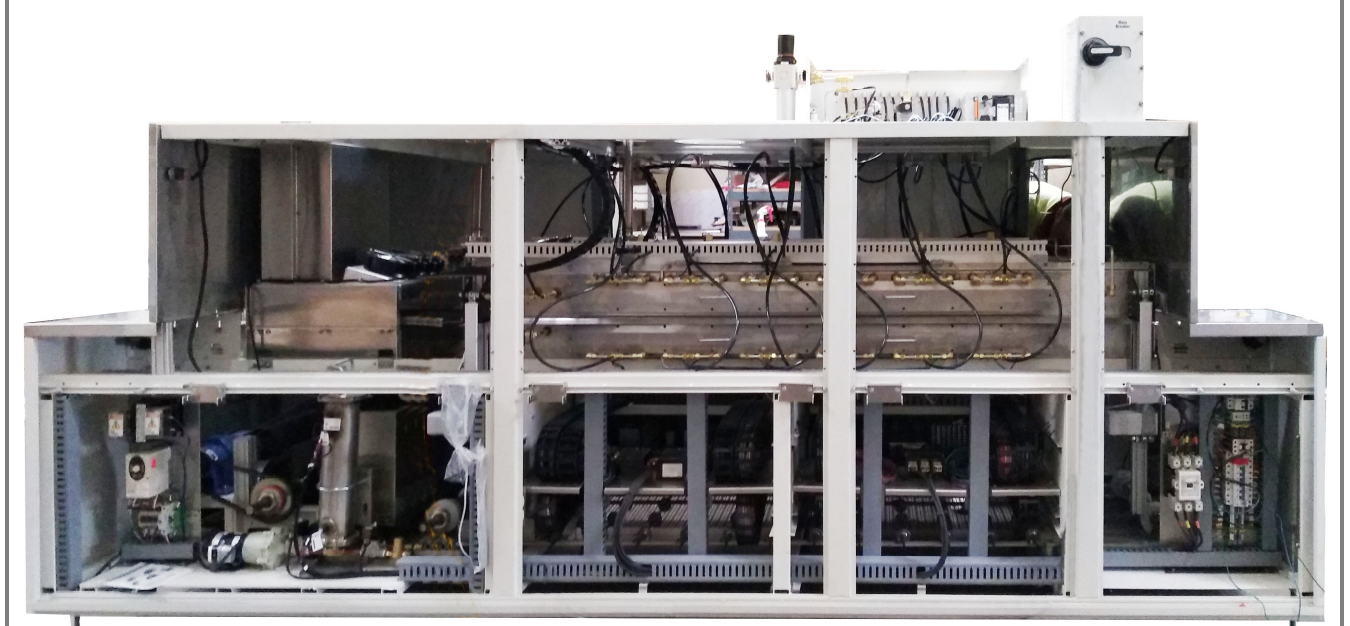

Figure 1-6 Rear, Panels Off

## Section 1

### 1.3 Furnace Elements

#### 1.3.1 Furnace Arrangement

During furnace operation, parts are carried from the load station through the heating and cooling sections of the furnace to the unload station on a 380 mm (15-inch) wide belt driven by an adjustable speed motor. Maximum vertical parts clearance inside the standard furnace is 50 mm (2 inches).

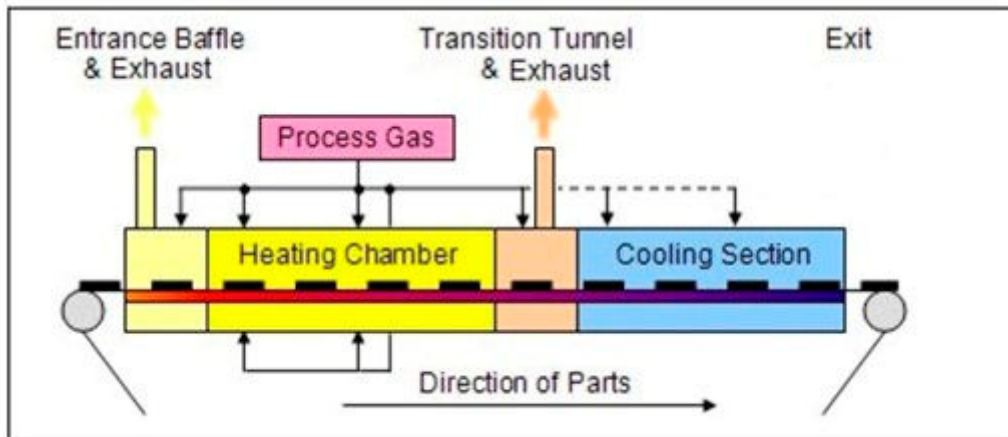

Figure 1-7 Process Sections

**Process atmosphere** is controlled much like a clean room: pressurized gas is pushed through the heating chamber insulated walls providing pre-heated, laminar flow for a uniform, stable atmosphere.

**Zones.** The heating chamber is divided into zones separated by insulating dividers so that adjacent zones can maintain different setpoint temperatures, if required. Control starts with K-type thermocouples in each zone quickly sensing changing conditions and feeding these signals to the PLC which communicates with the furnace computer. The furnace software PID loop algorithms control arrays of IR quartz heating lamps inside the heating chamber so as to maintain the desired temperature setpoint in each zone.

**Product cooling** is by radiant cooling and CDA or N<sub>2</sub> gas convective cooling in an enclosed tunnel, with exterior fan heat removal.

#### 1.3.2 Heat Transfer Methods

Transfer of heat in the furnace is by three different methods: Radiation, Convection and Conduction. In order of their contribution to heating the product, these methods are:

##### A. Radiation

The furnace lamps emit infrared electromagnetic waves which, when striking and absorbed by product on the belt, cause its temperature to rise. “Heat lamps” and microwave ovens work in a similar manner and it is also the way the sun heats the Earth. The infrared radiation does not directly heat the process gas within the furnace.

##### B. Convection

During operation, lamp radiation heats the chamber top, bottom and side wall insulation. As the process gas enters the furnace through the porous ceramic insulation, it is heated to near the setpoint temperature of the zone. This flow of heated gas transfers heat to the product on the belt. Hair dryers and home forced air heating function in the same fashion.

##### C. Conduction

Lamp radiation heats the transport belt which becomes a heat source for the product supported on the belt. Electric stoves and hot plates heat in this way.

#### 1.3.3 Controlled Atmosphere

TPS furnaces are equipped with the ability to supply constant streams of a supplied process gas. This feature allows the user to reduce product oxidation or contamination, remove process effluents or reduce other potentially negative effects of ambient air at high temperatures.

A controlled atmosphere also helps establish higher consistency in thermal processes. When a product travels through the process section, slight changes in the atmospheric conditions in a non-controlled atmosphere environment can affect the stability and consistency of the product temperature profile.

### 1.3.4 Flowmeters, Separate Chamber Top & Bottom

Each furnace chamber area with a flowmeter is plumbed with a separate flowmeter for the chamber top and bottom. Allows for separate control of process gas flow above and below the belt.

### 1.3.5 Hermetically Sealed Systems

For most furnace systems, the lamps ends are enclosed in plenums. Gas fed to the plenums keeps the lamps cool and prolongs the life of the lamp and improves lamp IR performance. Balancing the furnace gas inflows and outflows enables the furnace to maintain a hermetic seal. While not air-tight, a hermetic seal resists the mixing of the outside atmosphere with the furnace atmosphere by maintaining a higher pressure inside the furnace chamber. Adjust PLENUM TOP and BOTTOM flowmeters to cool lamp ends and maintain stable furnace atmosphere.

### 1.3.6 Furnace Process Equipment

The furnace process equipment consists of the furnace chamber including entrance baffle, furnace chamber and rapid cool transition tunnel and a fan cooled section configured for 50mm (2-inch) product height (PH2), arranged as shown in Figure 1-8.

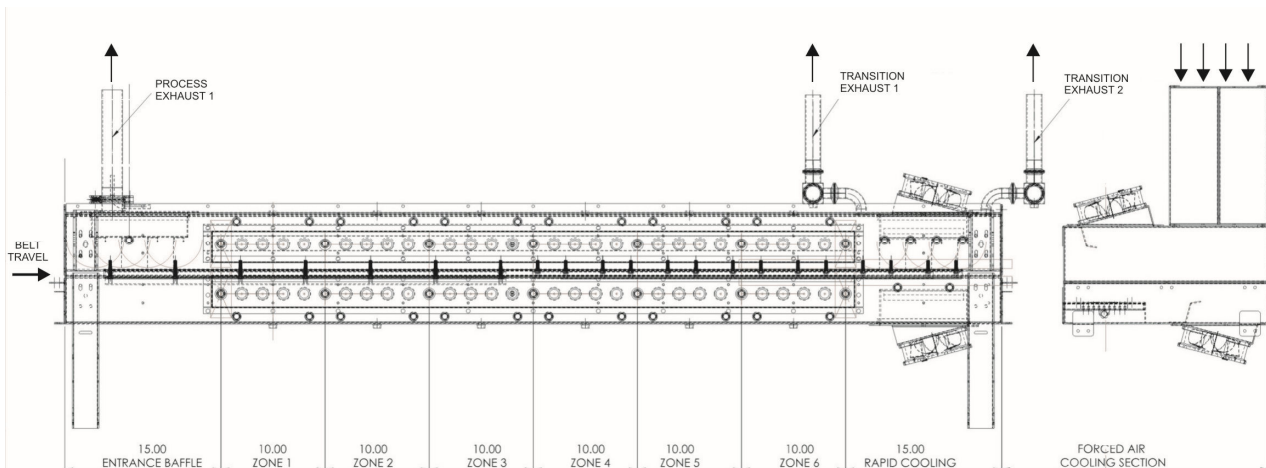

**Figure 1-8 Furnace Internals**

Together, the individual sections function as a unit to provide a carefully controlled gas atmosphere, precise temperature profile and controlled cooling.

### 1.3.7 Load Station (LOAD)

Located immediately before the furnace entrance, the Load station consists of two (2) horizontal stainless steel surfaces 371 mm (14.6 inches) long x 400 mm (16 inches) wide positioned on either side of the belt. The Load station provides a convenient area for handling product and for holding profiling equipment.

### 1.3.8 Furnace Chamber

The furnace chamber comprises the heat processing section consisting of one long chamber divided into three major sections. In the direction of the belt travel, these sections are the Entrance Baffle, Heating Zones and Rapid Cool Transition Baffle. The furnace chamber is a welded stainless steel shell lined internally with high temperature ceramic fiber insulation.

The heating chamber is divided horizontally with a remote motorized lift to allow separation of the top and bottom of the furnace chamber for inspection and maintenance when the furnace is down.

#### A. Entrance Baffle & Exhaust Stack (BE)

The 381-mm (15-inch) long entrance baffle in first section of the furnace chamber isolates the heating zones from the ambient air outside the furnace entrance. A process gas curtain with a series of hanging swinging

## Section 1

stainless steel baffle plates serves to act as a thermal barrier as well as purge the baffle and help prevent ambient air from entering the furnace. Owner can stipulate baffle clearance of 6 mm to 40 mm (0.25 to 1.5 inches) above the belt (or eliminate entirely). Your SMD-615 was shipped with 13 mm (0.50”) baffle clearance. Adjust gas flow to the ENTRANCE BAFFLE flowmeter to isolate Zone 1 from room atmosphere.

A venturi-assisted exhaust stack, or “eductor”, draws furnace gases out of the furnace. Before exhausting via the stack, the process gas passes over an accessible drip tray to collect exhaust condensation and prevent it from falling into the baffle section and contaminating the product. The eductor pulls 15 times its process gas flow from the furnace. Adjust gas flow to the ENTRANCE EXHAUST flowmeter to balance the furnace gas outflow with the gas inflow.

### B. Heating Zones

The heating zones follow the entrance baffle in a 762-mm (60-inch) long section of the furnace chamber divided into furnace zones that are hermetically sealed with plenum covers over the lamp ends. Inside this section, arrays of tungsten filament quartz heating lamp tubes located above and below the belt, generate intense near-wave (sometimes called “short-wave”) infrared light with a color temperature of 2500 K (peak wave length of 1.16  $\mu\text{m}$ ). These lamps are very efficient heaters with very fast response times, producing up to 1500 W per lamp at full power and capable of heating the furnace chamber to a state of equilibrium within minutes.

**Lamp Arrangement.** The lamps are arranged symmetrically above and below the belt. The top and bottom lamps may be used independently or together to configure the best possible heat transfer mode for each individual process. **Table 1-1 Furnace Arrangement** shows the distribution of lamps and available power in each zone. See 802-101501 Power and Current datasheet in Section 5 for more information of the distribution of lamps and available power in each zone.

Zone	Zone Length (mm)	Zone Length (inches)	Number of Lamps Top / Btm	T/B Available Zone Power (W) 415 Vac	Max. Available Zone Power (W) 415 Vac
1	254	10	4 / 4	1800	3600
2	254	10	4 / 4	1800	3600
3	254	10	4 / 4	1800	3600
4	254	10	4 / 4	1800	3600
5	254	10	4 / 4	1800	3600
6	254	10	4 / 4	1800	3600

**Power Configuration.** The SMD-615 furnace is wired half power in all zones to facilitate smooth and consistent delivery of heat energy. Zones 1 through 6 are each wired with one (1) string of lamps, each string consisting of four (4) lamps in series. This arrangement has been tested and will perform well throughout the design temperature range of the furnace (100-600 °C). Lamps within the furnace are arranged as shown in Table 1-2.

Chamber	Zone	Standard Configuration		Total Number of Lamps
		Strings Top/Btm	Lamps per String Top/Btm	
1	1	1 / 1	4 / 4	8
	2	1 / 1	4 / 4	8
	3	1 / 1	4 / 4	8
	4	1 / 1	4 / 4	8
	5	1 / 1	4 / 4	8
	6	1 / 1	4 / 4	8

**Control Zones.** The furnace heating chamber is partitioned into 6 separate temperature control zones using ceramic fiber dividers. The dividers are designed with the smallest possible opening consistent with the parts clearance specifications. This partitioning assures very high thermal isolation between zones. Although the heating profile across the belt is extremely uniform, heat losses through the furnace side walls and at the belt edge supports produce a temperature drop near the edges of the transport belt. Away from the extreme edges of the belt, overall temperature uniformity across the belt is normally better than  $\pm 3^{\circ}\text{C}$ .

**Edge Heaters.** The Edge heaters are resistance wire heaters that run parallel to the belt and provide a user-adjustable level of heat at the chamber sides. In critical applications, especially in furnaces greater than 14 inches wide, properly adjusted edge heaters can enable greater use of the furnace width because they make possible a flatter temperature profile across the width of the furnace often improving across the belt variation to  $\pm 1^{\circ}\text{C}$ .

Use the furnace software to add edge heat power (0-100%) in small increments to improve across the belt performance.

**Caution: because the edge heaters are controlled with a feedforward signal, addition of large amounts of edge heat power relative to lamp power can contribute to an instable operating condition.**

**Temperature Measurement.** Inside the furnace chamber, at the top center of each zone a type K thermocouple measures the temperature in that zone and provides feedback to each respective zone PID controller to determine the amount of power necessary to maintain setpoint temperatures. However useful these thermocouples are for controlling the temperature in each zone, the actual part is exposed to three heat transfer methods. As with any furnace, the most accurate way to determine what temperature product on the belt actually sees from these three methods of heating is to profile the furnace with a thermocouple placed directly on the product surface.

**Chamber Process Gas.** Process gas (CDA,  $\text{N}_2$ , FG or other gas) is preheated before reaching the furnace interior by allowing it to permeate through the hot porous ceramic fiber insulation. This method of gas distribution minimally affects the temperature profile and helps keep the furnace interior clean.

Adjust flowmeters for ZONE 1 through 6 to establish stable furnace operation and desired controlled processing atmosphere.

### C. Rapid Cool Transition Baffle (RCT)

The Transition Baffle is similar to the entrance baffle and consists of a 381-mm (15-inch) long transition tunnel with swinging baffle plates that separate the furnace heating section from the cooling sections. It is housed in a welded stainless steel shell lined with ceramic fiber insulation. An  $\text{N}_2$  gas curtain with a series of hanging stainless steel baffle plates serves to act as a thermal barrier as well as purge the baffle and help prevent ambient air from entering the furnace. Owner can stipulate baffle clearance of 6 mm to 40 mm (0.25 to 1.5 inches) above the belt (or eliminate entirely). Your SMD-615 was shipped with 13 mm (0.50") baffle clearance.

Adjust EXIT BAFFLE flowmeter to control product initial temperature drop and to isolate the furnace atmosphere from the cooling section.

Two venturi-assisted exhaust stacks, or "eductors" draw furnace gases out of the furnace. Before exhausting via each stack, the process gas passes over an accessible drip tray to collect exhaust condensation and prevent it from falling into the baffle section and contaminating the product. Each eductor pulls 15 times its process gas flow from the furnace. Adjust gas flow to the EXIT EXHAUST 1 and EXIT EXHAUST 2 flowmeters to rapidly evacuate heat and process atmosphere from the furnace as well as balance the furnace gas outflow with the gas inflow.

## Section 1

### 1.3.9 Water Cooled Section (CAWC) – option not included

The Closed Atmosphere Water Cooled section is an enclosed section with process gas air rakes for rapid cooling. Air rakes are mounted above the belt to improve transfer of heat to the water inside of the cooling jackets above and below the belt. This heat must then be extracted by an external chiller.

Water or other liquid coolant should be circulating through the CAWC jacket before the furnace is started. Adjust coolant flow rates at water flowmeters.

Adjust process gas flow rate by adjusting flowmeters for cooling 1 and cooling 2. Clockwise adjustment decreases gas flow to the air rakes, counterclockwise increases gas flow speed (Figure 1-9).

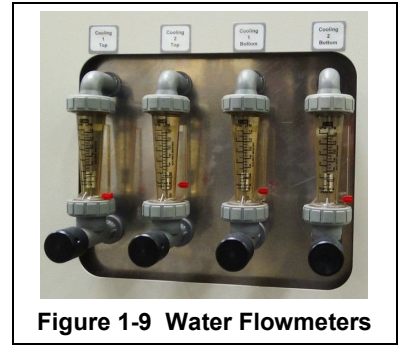

### 1.3.10 Open Belt Section

Following the rapid cool transition is a short section of open belt before the fan cooled section to isolate the furnace chamber from eddy flow generated in the fan cooled section.

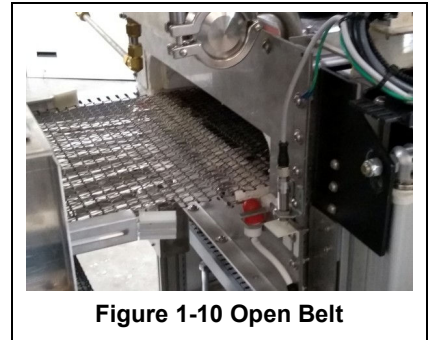

### 1.3.11 Fan-Cooled Section (FC)

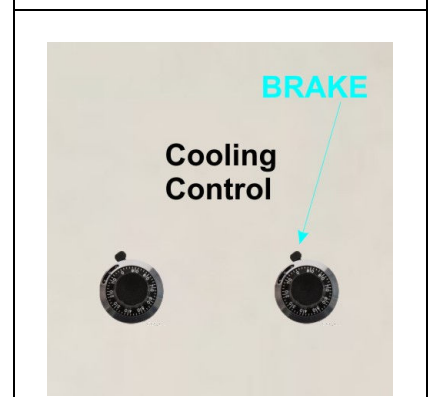



The fan cooling section is an open section with upper fan arrays to cool product before exiting the furnace. Fans mounted in enclosures above the belt transfer heat to the air inside of the furnace cabinet. This cabinet air is then exhausted by cabinet fans through openings in the furnace top cover into the room or for removal by facility exhaust ducting.

**Figure 1-12 Cooling Controls**

Adjust fan air flow rate by releasing the brake on the 10-turn knobs at the Control Console. Clockwise adjustment increases fan speed, counterclockwise decreases fan speed (Figure 1-12 Cooling Controls).

### 1.3.12 Unload Station (UNLOAD)

Located immediately after the final cooling stage exit, the Unload station consists of two (2) horizontal stainless steel surfaces 371 mm (14.6 inches) long x 400 mm (16 inches) wide positioned on either side of the belt. The Unload station provides a convenient area for handling and removing product exiting the furnace.

## Section 1

### 1.3.13 Atmosphere Supply Gas – CDA, Nitrogen & Forming Gas

Plant supply process gas must be filtered and regulated to 4.5-8 bar (65-120 psi) before the furnace is started to assure consistent clean dry process gas is supplied during furnace operation. An internal gas reservoir with check valve further regulates gas pressure to 15 psi for the belt tensioner.

If the furnace supply gas pressure drops below the set point during operation, the operator should put the furnace into Cool Down. The operator can reset the system to Warm Up when air pressure is again over 70 psig.

**Table 1-3 Gas Supply Pressure**

Location	Default Setting	
Plant Process Gas Regulator supply to furnace	65-70 psig	4.5 - 10.3 bar
Furnace Regulators (CDA, N <sub>2</sub> , FG)	70- psig	4.8 bar
Low Gas Pressure Alarm Switches	55-60 psig	3.8 - 4.1 bar

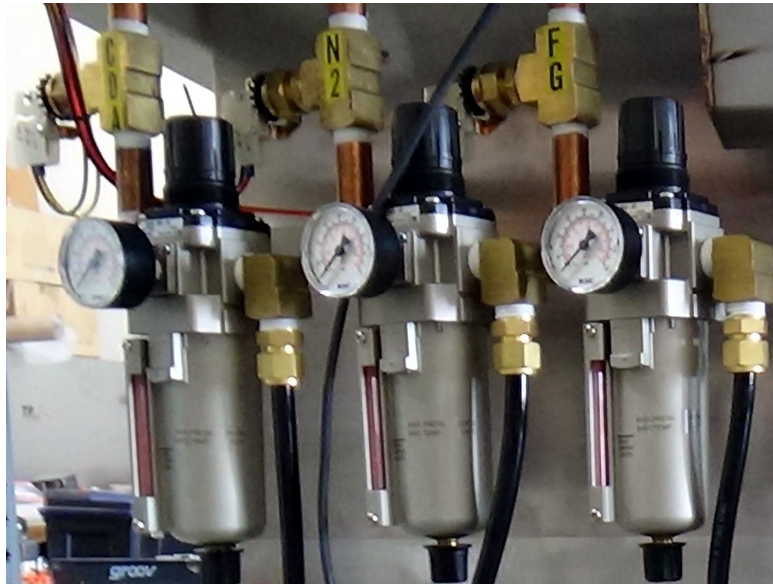

**WARNING: The flowmeters on these furnaces are rated at 70 psi (5 bar) maximum. Operating above 70 psi exposes the operator to possible injury, may cause damage to the furnace internals and insulation and voids the furnace warranty.**

See Section 3 for information calibration and service of the pressurized gas (N<sub>2</sub>/CDA) system.

## 1.4 Control System

This control system is comprised of a programmable logic controller (PLC) and computer interface (HMI).

### 1.4.1 Computer Interface (HMI)

The furnace control system uses a high quality industrial computer to manage user interface with the furnace controller and to store recipes. The furnace computer can also be used for profiling and other tasks.

The furnace computer is located in the 1<sup>st</sup> bottom drawer under the Control Console.



Figure 1-13 Furnace Computer

### 0.1.1 PLC

The furnace controller is a programmable logic controller consisting of a SNAP-PAC controller connected to a SNAP PAC-EB2 Brain and analog and digital analog input and output modules mounted on a rack.

The controller operates the furnace and connects via Ethernet to the furnace computer to receive instructions and to send information regarding the furnace operations and status.

The PLC controller is located in the 2<sup>nd</sup> bottom drawer from entrance, next to the furnace computer (Figure 1-15Figure 1-15).

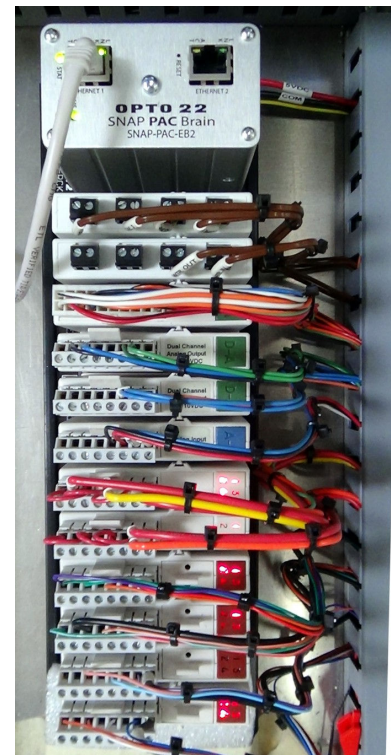

Figure 1-14 PLC Rack

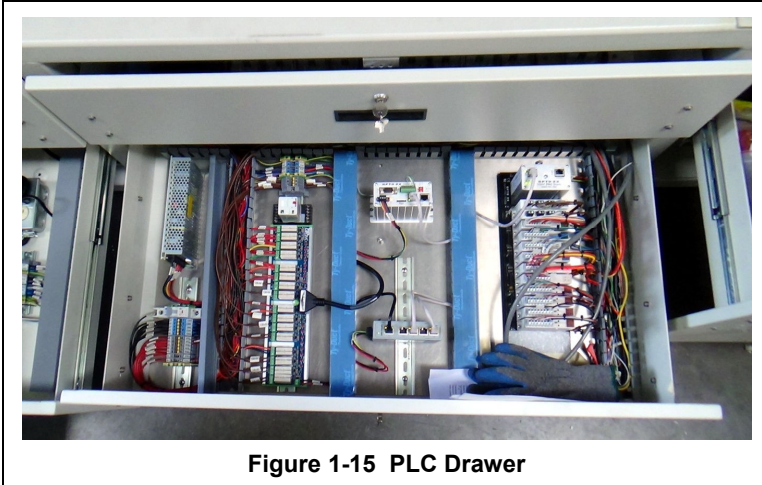

Figure 1-15 PLC Drawer

### 1.4.2 Controller

The SNAP PAC S1 programmable automation controller provides powerful, real-time control and communication to meet the furnace industrial control, monitoring, and data acquisition needs. The SNAP-PAC-S2 is a compact, industrially hardened controller that can handle multiple control, automation, and data acquisition tasks involving digital and analog control, serial string handling, PID, and enterprise connectivity. Connecting to Opto 22 serial and Ethernet-based I/O systems, the SNAP PAC S1 controller runs the furnace control programs written in Opto 22's PAC Control™ software to monitor and control all critical furnace functions.

The furnace controller continues to manage all aspects of furnace operation even if communication with the furnace computer is lost.



Figure 1-16 PAC-S1 Controller

### 1.4.3 I/O (Input / Output)

The SNAP-PAC-EB2 brain is an I/O and communications processor for the furnace control system. The SNAP-PAC-EB2 provides local intelligence that frees the PAC-S1 controller for supervisory tasks.

As an I/O processor, the SNAP PAC EB2 brain independently handles functions such as latching, thermocouple linearization, watchdog timers, and PID loop control. These functions continue to work in the brain even if communication with the SNAP PAC controller is lost.

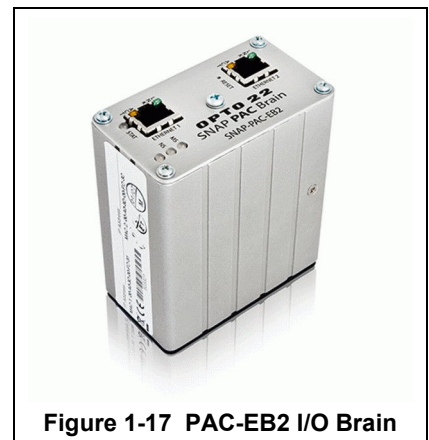
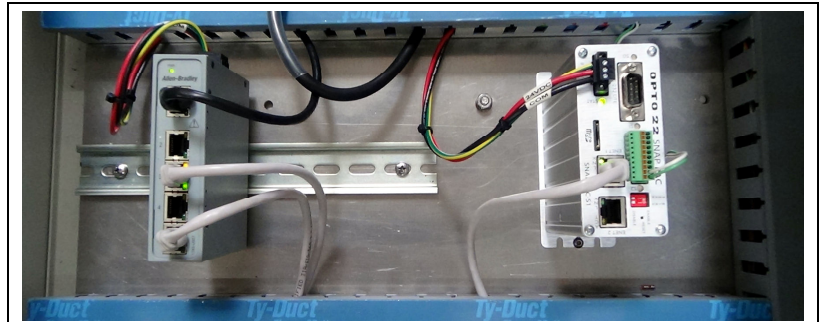

Figure 1-17 PAC-EB2 I/O Brain

## 1.4.4 Ethernet Switch

The furnace computer, SNAP PAC S1 controller and SNAP PAC brains and I/O communicate over standard 10/100 Mbps Ethernet networks and can be attached to existing wired or wireless Ethernet networks. The system includes an industrial Ethernet switch which provides connection to local intelligence and to digital and analog sensors and actuators as well as serial devices.



**Figure 1-18 Ethernet Switch (R) and Controller (L)**

Each of the devices and independent Ethernet ports have separate IP addresses. See Figure 1-19 Figure 1-19 Furnace network for typical furnace network configuration

### 1.4.5 Furnace Ethernet Network

The furnace network consists of the furnace computer, a SNAP PAC S1 controller and one or more SNAP PAC brains and I/O racks which communicate over standard 10/100 Mbps Ethernet networks and can be attached to existing wired or wireless Ethernet networks. A typical furnace network map is shown in Figure 1-19.

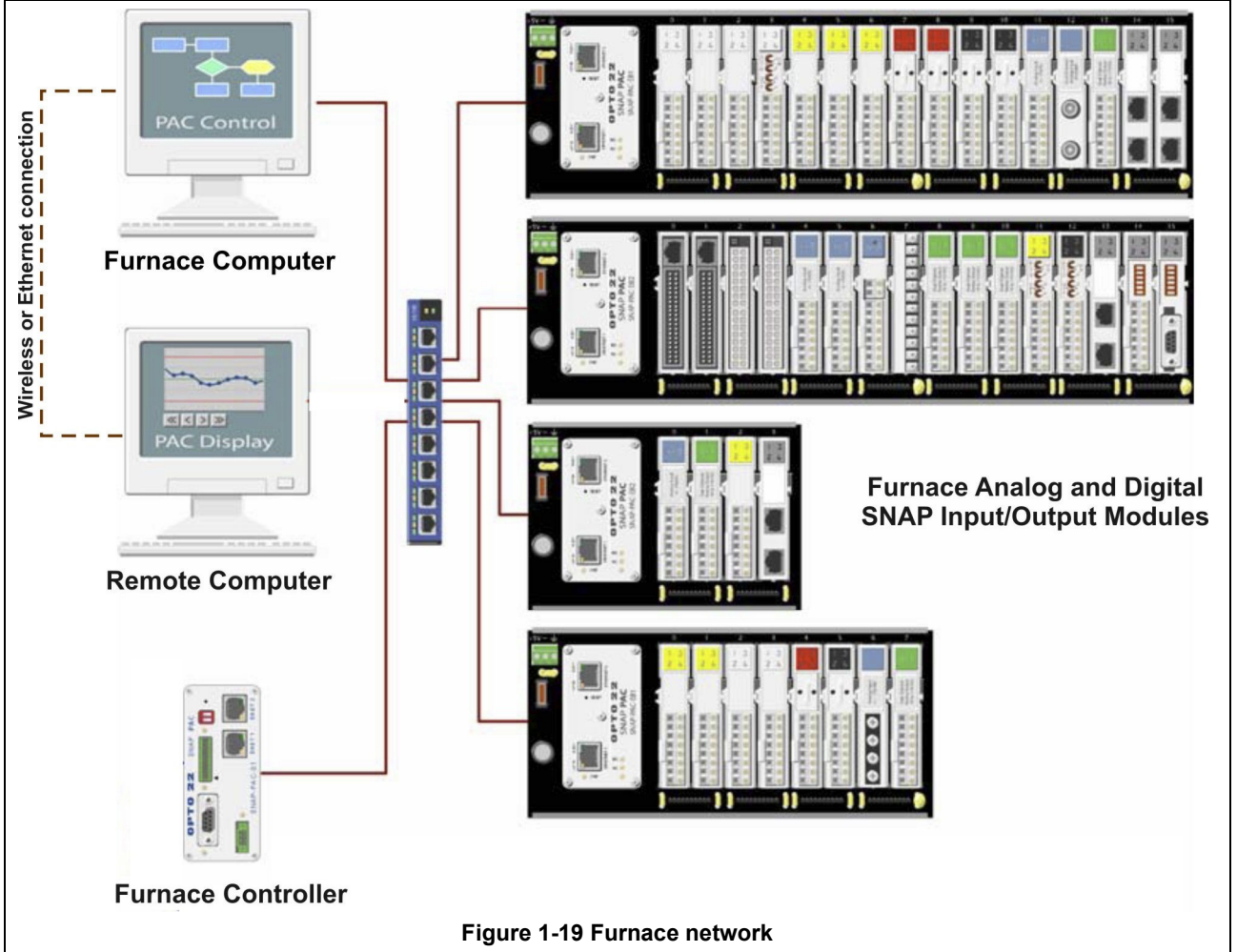

Figure 1-19 Furnace network

## 1.5 Auxiliary Equipment

### 1.5.1 Cabinet Exhaust

**Cabinet Vents.** The furnace is equipped with two (2) 10-inch diameter vent grills cut into the top of the furnace cabinet, one over the furnace heating sections and one over the water cooling section. These vents exhaust heat emitted from the outside of the furnace chamber and cooling tunnel into the room or customer installed exhaust system.

**Cooling System Fans.** The FC (forced cooling) system is cooled by fans mounted above the belt after the water cooling section. Cabinet air is forced over the belt to transfer heat from the belt and product on the belt. This air is evacuated via the cabinet fans mounted under the top of the cabinet near the furnace exit.

### 1.5.2 Low Pressure Alarms (IPS)

Gas Supply Pressure Switches are installed on critical process gas manifolds. These switches are normally closed. They open when proper pressure is present in the process gas supply lines.

The pressure switches are factory set to open when pressure falls below the pressure set points in Table 1-4 for Gas 1 and Gas 2.

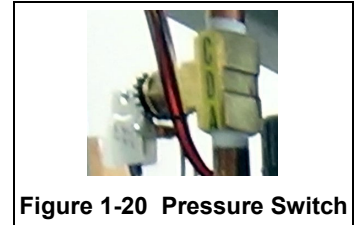

Figure 1-20 Pressure Switch

Table 1-4 Initial Pressure Alarm Settings				
Manifold	Process Gas	Design Pressure	Pressure Set Points	
Gas 1	CDA	70 psi (5 bar)	55-60 psi	3.8-4.1 Bar
Gas 2	Nitrogen	70 psi (5 bar)	55-60 psi	3.8-4.1 Bar
Gas 3	Forming Gas or other	70 psi (5 bar)	55-60 psi	3.8-4.1 Bar

The pressure switch set points can be adjusted manually. Locate the switch in the process gas supply line. To increase the set point turn the wheel clockwise. Turn the top of the switch counter clockwise to decrease the pressure set point so the alarm will not occur until the pressure drops to a lower point.

### 1.5.3 Belt Travel (LTR)

Standard direction for belt travel is from left to right when facing the furnace Control Console. As an option, the furnace can be configured for right to left operation. This arrangement allows two production furnaces to be easily operated by a single person.

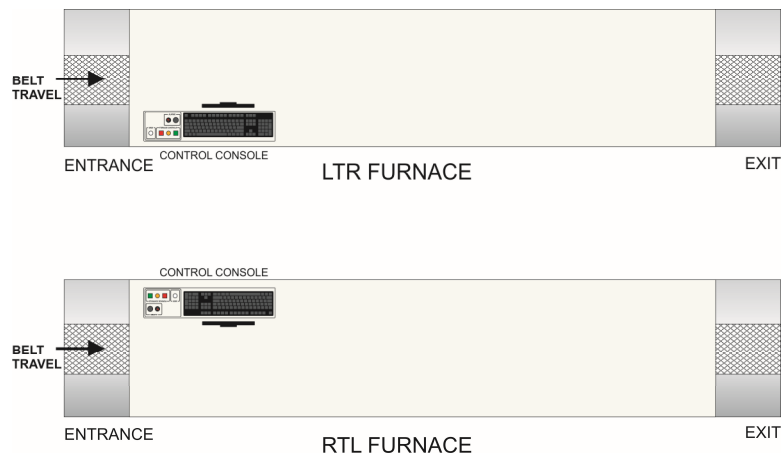

Figure 1-21 Direction of Belt Travel

## Section 1

### 1.5.4 Transport Belt

The standard conveyor belt is manufactured of 316 stainless steel as installed on this furnace.

For high temperature applications (>450°C) such as this one, the conveyor belt is a close weave Nichrome-V belt manufactured from high temperature wire comprised of 80% nickel and 20% chromium.

These belts offer fast heat-up times, more uniform operating temperatures and excellent mechanical stability. This belt exhibits minimum shrinkage, growth, sag or distortion in use.

### 1.5.5 Transport Drive Motor

The transport drive motor assembly is typically mounted near the exit of the process section. Depending upon belt width, product mass, product number and belt speed, the motor-sprocket may appear different than the example shown in Figure 1-22 Transport Drive Motor.

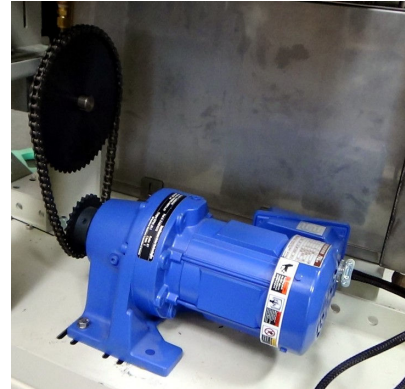

Figure 1-22 Transport Drive Motor

### 1.5.6 Universal Transformers

All primary transformers used in the furnace are manufactured specifically for our furnaces. These transformers are 50/60 Hz multi-tap and can be configured to operate the furnace at most commonly available voltages worldwide.

### 1.5.7 Factory UPS

Uninterruptable power supply to keep the computer, monitor and PLC controller running for at least six (6) minutes in the event the power to the furnace is disconnected or during a power outage. The UPS provides time for the operator to properly power down the furnace computer using the Windows operating system.

When the furnace loses power either by:

- Throw open furnace circuit breaker
- Open EMO or interlock
- Loss of facility power
- Press Furnace Control Panel OFF

The belt and all auxiliaries will stop, but the computer, monitor and PLC will continue to run. Use the Windows™ “Shut down” procedure to shut down the computer. The PLC will shut down after 6 minutes or so.

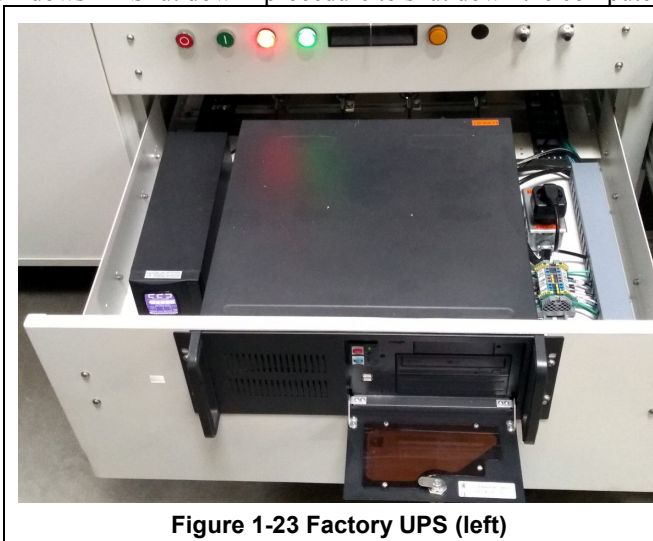

Figure 1-23 Factory UPS (left)



Figure 1-24 UPS, Rear View



## 1.6 Optional Equipment

Features and operation of the most common furnace equipment options that may have been included with the furnace or added later. See Table 1-5 for a summary of featured options. Unshaded items in bold were supplied on the furnace.

Table 1-5 Summary of Advanced Features & Options					
<a href="#">AFR</a>	<b>Air filter/trap regulator</b>	<a href="#">GSM</a>	Supply gas mixing system	<a href="#">OSS</a>	<b>Gas sampling system</b>
<a href="#">CB-3</a>	<b>3-phase circuit breaker</b>	<a href="#">HO/NHM</a>	H <sub>2</sub> operation N <sub>2</sub> /H <sub>2</sub> mixing	<a href="#">PH1, PH4</a>	25, 100 mm chamber height
<a href="#">CE</a>	CE mark	<a href="#">HSK</a>	<b>Handshake Signaling, Up/Dwn</b>	<a href="#">PPG</a>	<b>Pre-purge system, Nitrogen</b>
<a href="#">CXE</a>	<b>200 mm Load station extension</b>	<a href="#">LFI</a>	Line Interference Filter	<a href="#">RTL</a>	Right to Left Belt Travel
<a href="#">CXX</a>	<b>200 mm Unload station extension</b>	<a href="#">LT</a>	<b>Light Tower,3-Color Process Ready</b>	<a href="#">SMEMA</a>	<b>Product alert system</b>
<a href="#">DGO</a>	<b>Dual gas operation</b>	<a href="#">MA</a>	Moisture analyzer	<a href="#">SSP</a>	<b>Sample ports</b>
<a href="#">EM</a>	<b>Element Monitoring system</b>	<a href="#">OA</a>	<b>Oxygen Analyzer</b>	<a href="#">UCD</a>	Ultrasonic belt cleaner

### 1.6.1 Air Filter/Trap Regulator (AFR supplied option )

Each process gas supply line is provide with an air filter with moisture trap and pressure regulator to assure supply is properly pressure is clean, dry and at a safe pressure.

### 1.6.2 Circuit Breaker (CB-3 supplied option )

A three phase circuit breaker is installed on the rear side of the furnace near the entrance for convenient shutoff of the furnace when not in use. The circuit breaker is sized to prevent damage to the furnace. If the circuit breaker trips, reset by turning to ON position. If it trips again, shutdown furnace and trouble-shoot for high current draw. The CB-3 must be in OFF position to allow removal of the cover panel.

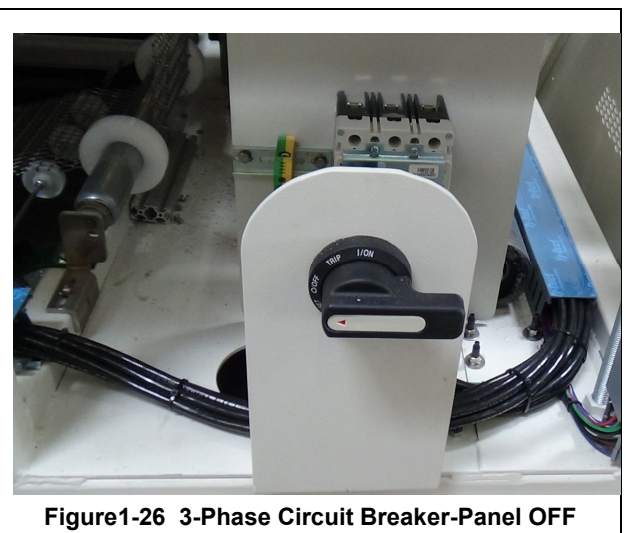
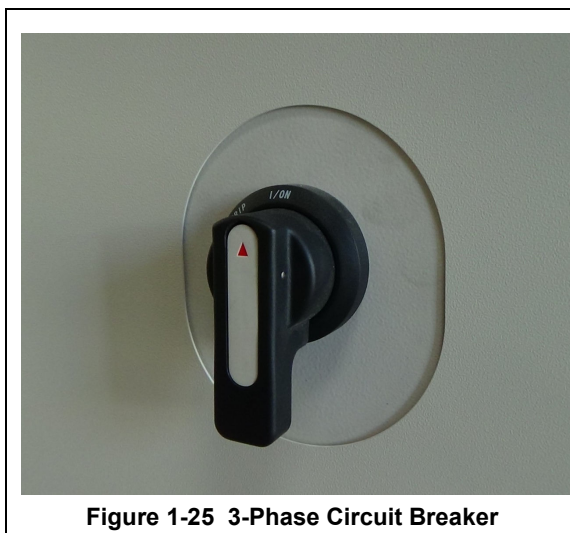

## Section 1

---

### 1.6.3 Load Extension (600 mm □, supplied)

Increases standard 400 mm (15 3/4-inch) stainless steel Load station at the entrance of the furnace in 200 mm (7-7/8-inch) increments. Useful if a longer product load area is needed. (Similar to Figure 1-27).

Increases furnace length by a like amount.

### 1.6.4 Unload Extension (600mm □, supplied)

Increases standard 400 mm (15 3/4-inch) stainless steel Load station at the exit of the furnace in 200 mm (7-7/8-inch) increments. Used for product inspection or to provide a longer period for product removal.

Increases furnace length by a like amount.



Figure 1-27 LA-309 Unload station with 600

**1.6.5 Three Gas, Dual Mode system (DGO supplied option ☐)**

Dual mode systems can allow a specialty gas to be introduced into the furnace chamber while another gas is provided to all furnace auxiliaries.

**A. DGO Equipment**

Includes separate manifold for supply of a different gas to the furnace heating zones (Furnace Gas2). Aux (Gas 1, CDA or nitrogen) is supplied to eductors, transition tunnels baffle sections and closed atmosphere cooling. Furnace (Gas 2) can be either the same as Gas 1, or Gas 2, forming gas or other specialty gas supplied to the furnace chambers and lamp plenums. The Control Console will sound an audible alarm and provide visual indication for a low Gas 1 or 2 supply pressure condition.

**B. Single Gas Operation (CDA or N2)**

A furnace plumbed for dual gas can be operated in single gas mode. To operate in single gas mode: To operate

1. Assure that gas is flowing from supply source at the proper supply pressure (70 psig).
2. To run furnace with compressed air in the furnace and auxiliary areas, select CDA Mode.
3. To run furnace with nitrogen in the furnace and auxiliary areas, select Nitrogen Mode.

The furnace will operate with the selected gas, CDA or nitrogen flowing to all auxiliary and furnace sections.

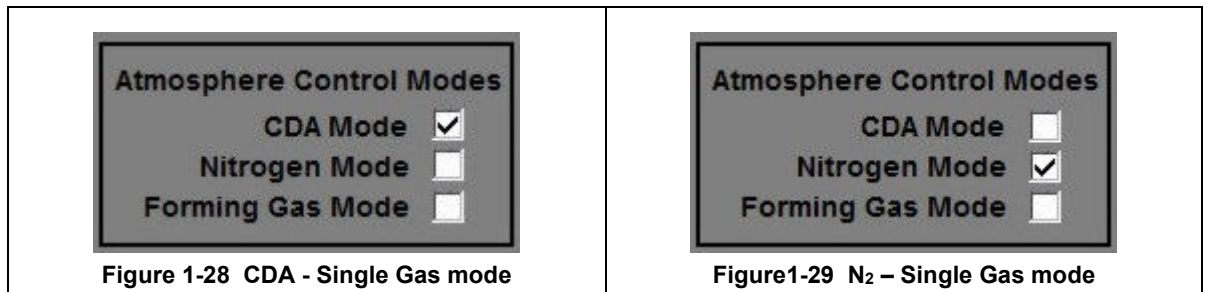

**C. Dual Gas Operation (FG & N2)**

A furnace plumbed for dual gas is operated in much the same way as a single gas furnace. To operate in dual gas mode:

1. Assure that gas is flowing from both supply sources at the proper supply pressure (70 psig).
2. On the Process Screen, Select Forming Gas Mode. Forming Gas will flow to the furnace chamber and plenums. Nitrogen will flow to all auxiliary areas.

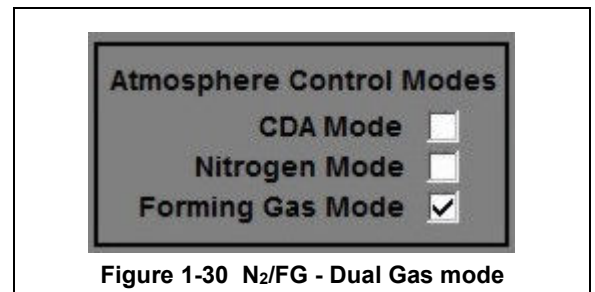

The furnace will operate with nitrogen flowing to the Aux furnace sections and Gas 2, forming gas or other alternate supplied gas flowing to furnace and lamp plenums.

## Section 1

### 1.6.6 Handshake (HSK, supplied option )

Normally Open and Normally Closed contacts supplied at entrance of the furnace that are activated when the furnace system is ready to receive a part (PROCESS\_READY).

Normally Open and Normally Closed contacts supplied at exit of the furnace that are activated when a part is sensed at the exit (PART\_AVAILABLE).

Facilitates notification to upstream and downstream equipment that the furnace is ready to process product.

### 1.6.7 Light Tower (LT, supplied option )

Three color light tower that indicates when furnace is in Process Ready, Warmup or Alarm condition.



Figure 1-31 Light Tower

### 1.6.8 Moisture Analyzer (MA option , not supplied)

For processes that are sensitive to moisture, a moisture analyzer can provide status of monitored zones.

The moisture analyzer can be connected to any one sample port (with SSP option) or can be used with a 3-port sample system (OSS option).



Figure 1-32 MM510 Moisture Analyzer

#### A. MA Equipment

The brand of moisture analyzer can generally be specified by the owner. A high quality choice, the MM510 electrolytic moisture analyzer is designed for precise measurement of moisture in gas over a wide range (0.1 ppm to 1000 ppm with  $\pm 5\%$  accuracy). The analyzer is configured with an internal sample pump. The sample systems are manufactured using stainless steel throughout with 1/8-inch tube connections on the sample line. Sample flow is 0.05-0.5 L/min (50-500 cc/minute) controlled.

**MM510 Sensor.** The phosphorus pentoxide moisture sensor consists of a dual platinum winding formed around a quartz tube about 8 cm long. A constant voltage is applied across the windings and the current monitored. The moisture in the sample gas stream causes the resistance of the platinum coil to change. The change in resistance results in a change in measured current providing an absolute measure of the moisture contained in the process sample gas. Unlike aluminum oxide sensors, the phosphorus pentoxide sensor does not require annual factory calibration.

#### B. MA Operation

The model of moisture analyzer selected will be factory set for your application.

1. Startup of the furnace will start the moisture sampling if the analyzer is left enabled by the operator.
1. A switch on the back of the analyzer allows shutoff of the analyzer while the furnace is running, if desired.
2. Sample line flow is controlled by the valve knob on the back of the analyzer Adjust to 0.15 L/min.

## 1.6.9 Oxygen Analyzer (OA, supplied option )

This furnace is equipped with an oxygen analyzer and 3-port sampling system with source gas purge.

An oxygen analyzer can assure furnace settings result in a low oxygen environment in the furnace chamber during operation.

The EC913 process oxygen analyzer uses an electrochemical RACET<sup>™</sup> cell for accurate measurement of oxygen (measuring range: 0.1 ppm-30% at ± 2%) and features microprocessor controlled functions, large auto-ranging LED display, and fast response. To avoid interference, indicate if hydrogen gas will be present.

The analyzer is fitted with an integral sample pump downstream of the sensor. The sample Out valve on the back of the analyzer is used for flow control and is adjustable from 0.05-0.5 L/min (50-500 cc/min) sample rate (default is 0.1 to 0.15 L/min).

On furnaces, the oxygen analyzer is usually mounted inside the furnace cabinet enclosure. The analyzer is integrated with the furnace control system. The oxygen concentration is displayed on the computer screen. Alerts and alarms are set in the process recipe on the computer.

Figure 1-35 shows the O2/MA Sample system control panel on furnaces equipped with a PC computer. The oxygen concentration for the selected zone is shown on the Process screen.



Figure 1-33 EC913 Oxygen analyzer

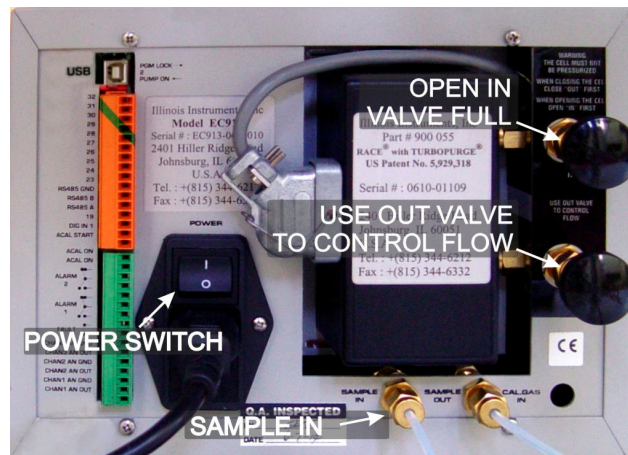

Figure 1-34 Oxygen analyzer next to OSS sample system

**During initial startup**, adjust OUT valve until Sample Flow flowmeter on front of analyzer reads 0.1-0.15 L/min. On subsequent startups, the flow rate does generally not need to be adjusted.

**Note A:** When the sample line is dry, accurate readings can be obtained within minutes. If the sample line contains moisture, it may take from 20 minutes or longer. Moisture may be purged from the sample line by disconnecting the line from the analyzer and using a dry gas (nitrogen) to flush the line. Be careful to keep the pressure under 2.5 bar (35 psig) to avoid disconnecting the sample line from the furnace.

**Note B:** When nitrogen is connected to Gas 1, Port Select S will sample the source nitrogen. Ports 1, 2 and 3 sample the respective furnace zones.

### 1.6.10 Sample System, Computer (OSS, supplied option )

OSS option provides user selection of any one of 3 furnace ports or the source gas (nitrogen) to a sample gas line connected to the gas analyzer equipment (typically moisture and/or oxygen analyzer).

#### A. OSS Equipment

This system consists of electrical controls and piping of a 4-port manifold to a source gas and 3 sample ports. The sample ports are located on the bottom of each furnace chamber zone. The Source is piped from Gas1 (or the nitrogen source) through a pressure regulator adjusted to 35 mbar (0.5 psig) and connected to port 1 on the manifold.

#### B. OA Operation (Process Engineer level)

Start furnace and furnace software.

On the Process screen:

- select **O2 Port Select** button to open the O2 Sampling popup,
- click **O2 Sampling** radial button until **ON** is displayed to energize or de-energize system,.
- Energizing O2 Sampling opens the selected port and starts analyzer and sampling pump.

System begins sampling the selected port. When starting system and changing ports, allow sufficient time for pump to completely purge sample.

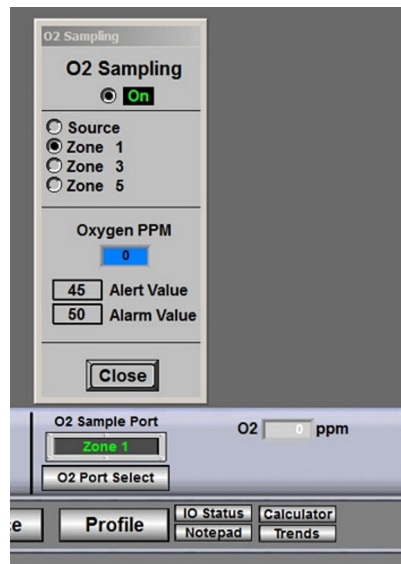

Figure 1-35 O2 ppmv and popup on Process screen

**Note:** When the sample line is dry, accurate readings can be obtained within minutes. If the sample line contains moisture, it may take from 20 minutes or longer. Moisture may be purged from the sample line by disconnecting the line from the analyzer and using a dry gas (nitrogen) to flush the line. Be careful to keep the pressure under 2.5 bar (35 psig) to avoid disconnecting the sample line from the furnace.

#### C. OA Operation (Operator level)

Sampling system On/Off state and selected port are stored in each recipe. To enable system:

On the Recipe screen:

- Get recipe with **O2 Sampling and Port Select** predetermined in the recipe.
- O2 sampling will start when the furnace is started if the sampling system is enabled in the recipe.

#### D. Initial Startup

During initial startup, adjust analyzer OUT valve until Sample Flow flowmeter on front of analyzer reads 0.1-0.15 L/min (**Error! Reference source not found.**). On subsequent startups, the flow rate does generally not need to be adjusted.

#### E. Purging Sample Lines

See section for using the sample system manual purge feature.

#### F. Shut Down Sampling System

On the Process Screen, click on O2 Sampling radio until **OFF** is displayed. Analyzer and pump shut down and sample system is isolated.

#### G. Shut Down Analyzer (long term shutdown)

If the analyzer is to be out of service for a period of time, further isolate the cell to prolong its life.

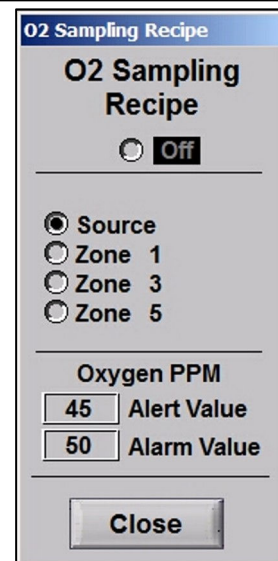

Figure 1-36 Sampling Recipe popup

If system is not equipped with a check valve on the Sample OUT line, close OUT valve on back of analyzer (to isolate cell).

If analyzer is disconnected from the OSS, Close IN valve on back of analyzer (to isolate cell).

**Note A: Analyzer valves can be left in open position while connected to the furnace as the sample port manifold will isolate the analyzer cell from gas flow when the system is off.**

**Note B: To prolong cell life, limit sampling of air.**

1.6.11 SMEMA Product Alert (option □ )

The SMEMA system alerts operators when product enters and exits the furnace. With the HSK handshake feature, the system provides SMEMA 1.1 Busy/Board\_Available signal generation to coordinate product handling from upstream and downstream equipment.

Detectors at the entrance and exit of the furnace system (Figure 1-37) will generate a **BUSY** or **BOARD\_AVAILABLE** signal. If a **BUSY** signal at the entrance or a **BOARD\_AVAILABLE** signal at the exit persists for more than a fixed period of time (3 seconds), a board jam may be considered to have occurred. The conveyor motion will not be stopped in the event of a jam, but the machine goes into Cool-Down and an Alarm condition is displayed.

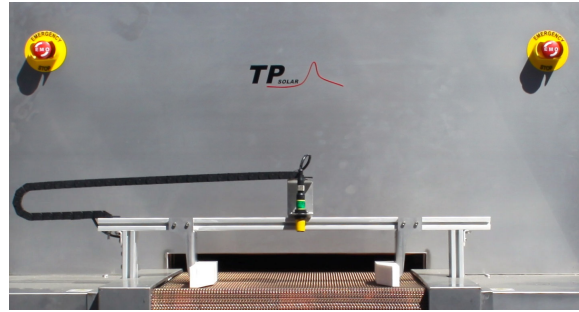

Figure 1-37 SMEMA Sensor



Figure 1-38 SMEMA Sensor

**A. SMEMA Equipment**

The SMEMA system consists of sensors located at the entrance and exit above the belt that send signals to the software when parts are detected. Each sensor is mounted on an extruded bar that allows the sensor to be placed anywhere across the belt.

**B. SMEMA Operation**

Easy to operate, activate the SMEMA product sensing system by clicking on the radio button below SMEMA button on the furnace software title bar to turn the system ON or OFF. Each time product passes under the entrance sensor, the Parts IN counter will increment. Each time product passes under the exit sensor, the parts OUT counter will increment. Running totals for each are shown on the title bar.

**C. Sensor Recipe Settings**

The purpose of the product sensor and on-screen tracking feature is to count the number of product units travelling through the furnace. A set of sensors at the entrance and exit detect the leading edge of a product unit leaving the loading station or arriving at the unloading station. The tracking feature sets off an alarm if the exit sensor does not detect the arrival of an expected product unit at the unloading station. The product unit length must be set in the Recipe screen (see figure 0-31)

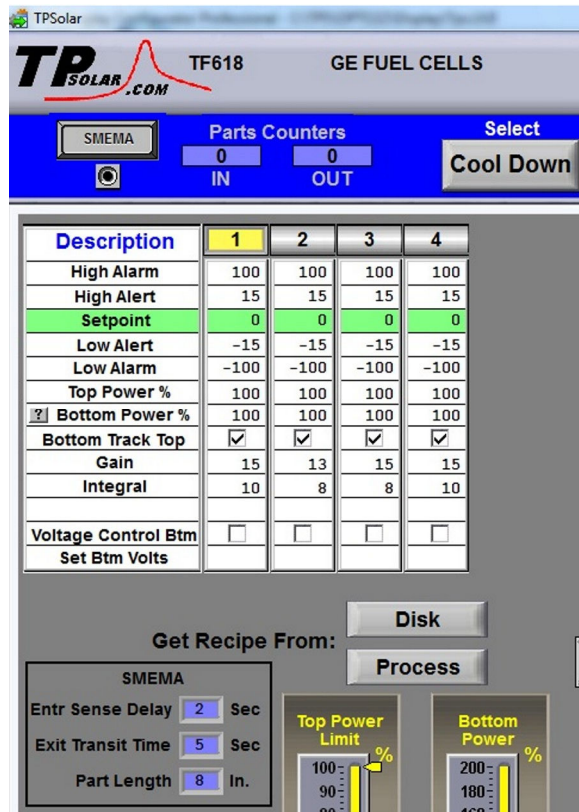

Figure 1-39 Screen showing Product Tracking settings

To initiate count, activate one or more tracking lanes by clicking the lane radial buttons on the upper left corner of the process screen.



**Entr Sense Delay** (seconds) is the time after the sensor detects the part to it being counted IN and the Furnace\_Ready signal is sent to the upstream equipment HSK contacts.

**Exit Transit Time** is the time it takes a part to travel from the Exit sensor to the end of the belt where the next machine gets the part. The **Boat\_Available** output signal is turned ON after the amount of time set in Exit Transit Time field as a signal to the next machine that there is a part ready to be acquired at the exit. Enter Exit Transit time in seconds.

**Part Length** field on the Recipe screen is used to determine the time it takes for a part to pass the Exit Sensor. This time is 1.5 times the part length divided by the belt speed. This time is used to ignore false readings as the part passes by the sensor. Enter the part length in inches.

### D. Product Tracking Sensors

The Product Tracking Sensors are self-contained fixed-field 880 nm infrared diffuse mode sensors located at the entrance and exit of the furnace. Their high excess gain and fixed-field technology allow them to detect objects of low reflectivity, while ignoring background surfaces. The cutoff distance is fixed. The most common furnace sensor model has a cutoff of 100 mm (4 inches). Backgrounds and background objects must always be placed beyond the cutoff distance.

Part Number	Sensor Model	Output	Range (cutoff)
350-79752-25	S18SN6FF25	NPN	25 mm (1 inch)
350-79752-50	S18SN6FF50	NPN	50 mm (2 inches)
350-79752-01	S18SN6FF100Q	NPN	100 mm (4 inches)

**Table 1-6 Product Tracking Sensor Range (cutoff distance)**

The Sensor compares the reflections of its emitted light beam from the product unit back to the sensor's two differently aimed detectors. If the near detector light signal is stronger than the far detector light signal, the sensor responds to the object. If the far detector light signal is stronger than the near detector light signal, the sensor ignores the object.

The cutoff distance is fixed (see Table 0-6). Objects lying beyond the cutoff distance usually are ignored, even if they are highly reflective. However, it is possible to falsely detect a background object under certain conditions. False sensor response will occur if a background surface reflects the sensor's light more strongly to the near detector (sensing detector) than to the far detector (cutoff detector). The result is a false ON condition. To cure this problem, angle the sensor slightly so the background does not reflect light back to the sensor.

An object beyond the cutoff distance moving past the face of the sensor can cause unwanted triggering of the sensor if more light is reflected to the near detector than to the far detector. The problem is easily remedied by rotating the sensor 90°. The object then reflects the two fields equally, resulting in no false triggering.

**Sensor Indicators.** The sensor features two LED sensors (green and yellow). See table 2 for guide.

Indication	Condition
Green ON Steady	Power to sensor is ON
Green Flashing	Output is overloaded
Yellow ON Steady	Normally Open (NO) output is conducting
Yellow Flashing	Excess gain marginal (1 to 1.5x) in light condition

**Table 1-7 Product Sensor Indicating Lights**

**Sensor Wiring.** See table 0-8 and drawing 802-101777 for sensor hookup and wiring guide.

Wire color	Designation
Brown	+24 Vdc
Blue	dc common
Black	Normally Open (NO) output (not used)
White	Normally Closed (NC) output to Furnace PLC

**Table 1-8 Product Sensor Wiring**

### 1.6.12 Sample Ports (SSP option )

This option includes control enclosure port connection to one or more of the sample ports located on the underside of each zone. Allows connection of an oxygen analyzer, moisture analyzer or other gas analyzer. Must be used with a sample pump (not included). Port connections are located under chamber. Figure 1-40 shows a typical port location on a chamber. Note: The chamber is fitted so that even if this option is not included at the time of manufacture, sample ports can be added later, if required.

Included with OA, MA and OSS options.

This furnace is equipped with 4 ports. Ports on zones 1, 2 and 3 are connected to the OSS sample system. The port on zone 4 is connected to a port on the front of the Oxygen analyzer drawer for easy connection of a user provided analyzer.

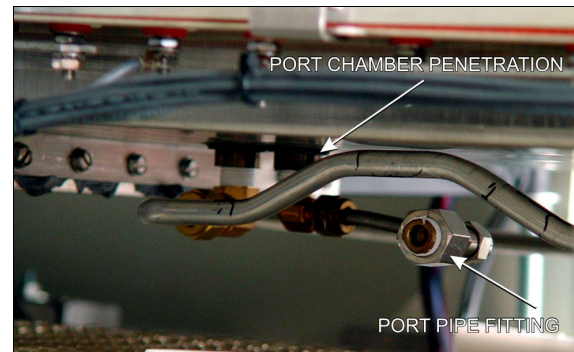

**Figure 1-40 Sample Port Chamber Penetration**